

Installation Guide

Boiler Room Systems

A better
approach to
radiant Heating
systems

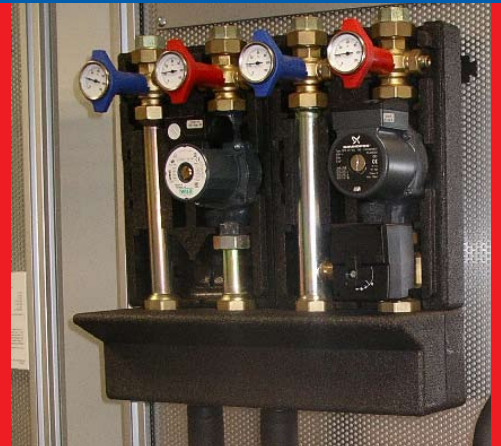

Radiant Heating and Snowmelting products

ComfortPro Systems
AquaHeat

System Design and Installation

The Mains

PEX pipe mains are recommended to reduce labor and architectural impact. For a slab-on-grade installation, the mains can be buried below or within the slab. For below slab installation refer to insulated supply and returns like ComfortPro Systems Microflex product range. For a wet or dry on plywood application, the mains can be installed within the joist cavity. Always allow for the expansion and contraction of the mains, as the temperature fluctuates. It is recommended that the pipe be allowed free movement and is not fastened directly to the floor joists.

Requirements of a hydronic control system

The intent of a hydronic heating control system is to achieve heating comfort, system protection, energy saving and ease of use.

Heating comfort is achieved by:

- keeping proper system temperatures
- directing the right amount of heat when and where you want it

System protection is achieved by:

- protecting the primary heat source (e.g. boiler) from corrosion and thermal shock
- reducing equipment cycling

Energy saving is achieved by:

- running the system at the lowest water temperature possible
- turning off the system when no heat is demanded
- minimizing boiler short cycling.

Ease of use is achieved by:

- running automatic functions in lieu of manual settings
- providing easy and consistent wiring and installation procedures

AquaHeat Installation Guide Philosophy

A hydronic system can get quiet complicated and with the rapid introduction higher integrated solutions keeping up is challenging more than ever. To keep the basic installation order we have build this guide to reflect the typical steps in the implementation of a project:

Chapter 1 - Hydronic floor installation

2 Chapter 2 - Manifold installations

Chapter 3 - Boiler room installations

Chapter 4 - Control system installation

Chapter 5 - System start-up, warranty requirements and maintenance

Chapter 3 - AquaHeat Boiler Circuit Heating Systems

Hydronic Heating System Control Strategies	4
Using boiler control	4
Constant water circulation	4
Varying water temperature	5
Boiler System control	5
Set point control	5
ProMix Boiler Module Application	8
ProMix Non-Mixing Boiler Module	8
ProMix Mixing Boiler Module	8
Technical Data	9
Selecting the circulator pump	9
Installation Instructions for ProMix Boiler Modules	10
Connect ProMix boiler modules	10
3-way mixing valve motor assembly	11
Wiring the ProMix boiler modules	11
Switching Supply and Return sides	12
ProMix Header Modules	13
Installation of ProMix Header modules	13
Use of multiple Header/Boiler Modules	14
Serial Header Combination	14
Parallel Header Combination	14

Hydronic Heating System Control Strategies

Generally, hydronic heating control systems can be placed into two categories:

- constant water circulation
- intermittent water circulation

Each of these categories can be further divided into a:

- system where water temperature is fixed or constant.
- system where water temperature varies in response to changes in outdoor air temperature and/or indoor air temperature.

Using boiler control

The use of an indoor/outdoor boiler control works well with a condensing boiler and single circuit heating system. All boilers have aquastats that control output water temperature within a user's set range. The simplest type of control system uses a boiler with controls set to deliver a fixed temperature output every time the thermostat calls for heat. As heat loss increases from the building at colder outdoor temperatures, the boiler will run longer to meet the heat demand.

The water temperature supplied to the floor is preferably kept as low as possible if not a ProMix Isotherm module is included in the manifold injection loop (see chapter 2). This minimizes the possibility of overshooting the set indoor temperature when the floor heating system calls for heat.

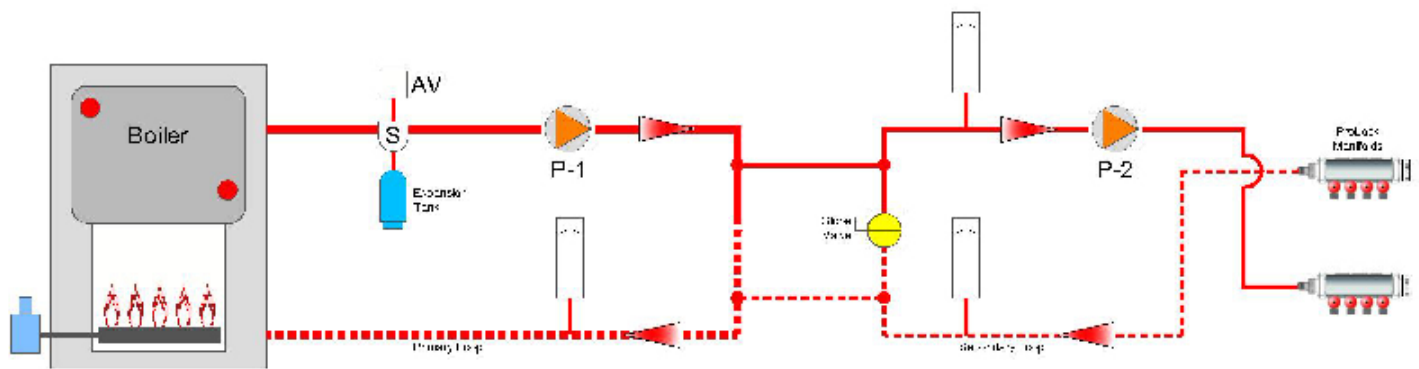

Fig 1 -

Constant water circulation

With a pump running constantly, boiler circuit or zone valves are turned on and off by thermostats in response to indoor air temperatures.

- In a single circuit heating system, water is circulated constantly through the boiler when there is a call for heat and the boiler is turned on and off.
- In a multiple circuit environment, water is circulated constantly through the boiler, but is circulated intermittently through each individual zone when a room temperature sensing device (thermostat) turns the zone valve on or off.

Usually the water temperature in the floor is controlled by a boiler control device, and/or a mixing device. The purpose of a mixing device is to mix return water from the system with the supply water to:

- Protect the Boiler from too low a return temperature
- Provide the temperature to the floor as low as possible

Varying water temperature

For greater energy saving, the water temperature feeding the floor heating system is allowed to vary in response to the changes in the outdoor/indoor air temperature. It can be done manually or by an indoor/outdoor controller (an automatic device). To avoid a situation of extremely cold water (from a cold system startup) returning to a boiler, the boiler is to be set at a minimum water temperature for protection and the return water is mixed.

Boiler System control

For proper system control, a piping layout to allow primary and secondary pumping off the boiler is recommended.

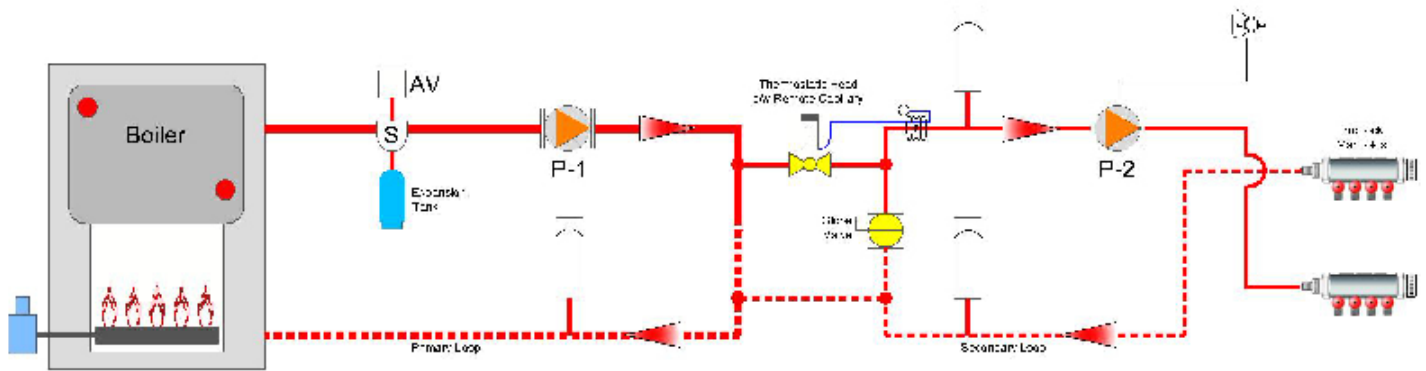

Fig 2 - Primary and secondary water circulation

Set point control

Advantages:

- simple installation
- inexpensive

Disadvantages:

- single water temperature set point
- must rely on room thermostat to avoid possible overheating
- no boiler protection

AquaHeat provides easy mountable mixed water use modules to facilitate the specific conditions of individual heating circuits. An example of the use of ProMix boiler modules is sketched below. In this case the module pumps provide flow through the boiler.

This design needs to meet both of the following requirements:

- Minimum possible flow through any single circuit exceeds the boiler’s minimum flow requirement
- Low water return temperature does not harm the boiler

If these requirements cannot be met we recommend using boiler loop layout #2 where the use of a primary and a secondary pump circuit is used.

Boiler loop layout #1: Boiler module as primary boiler loop circulator

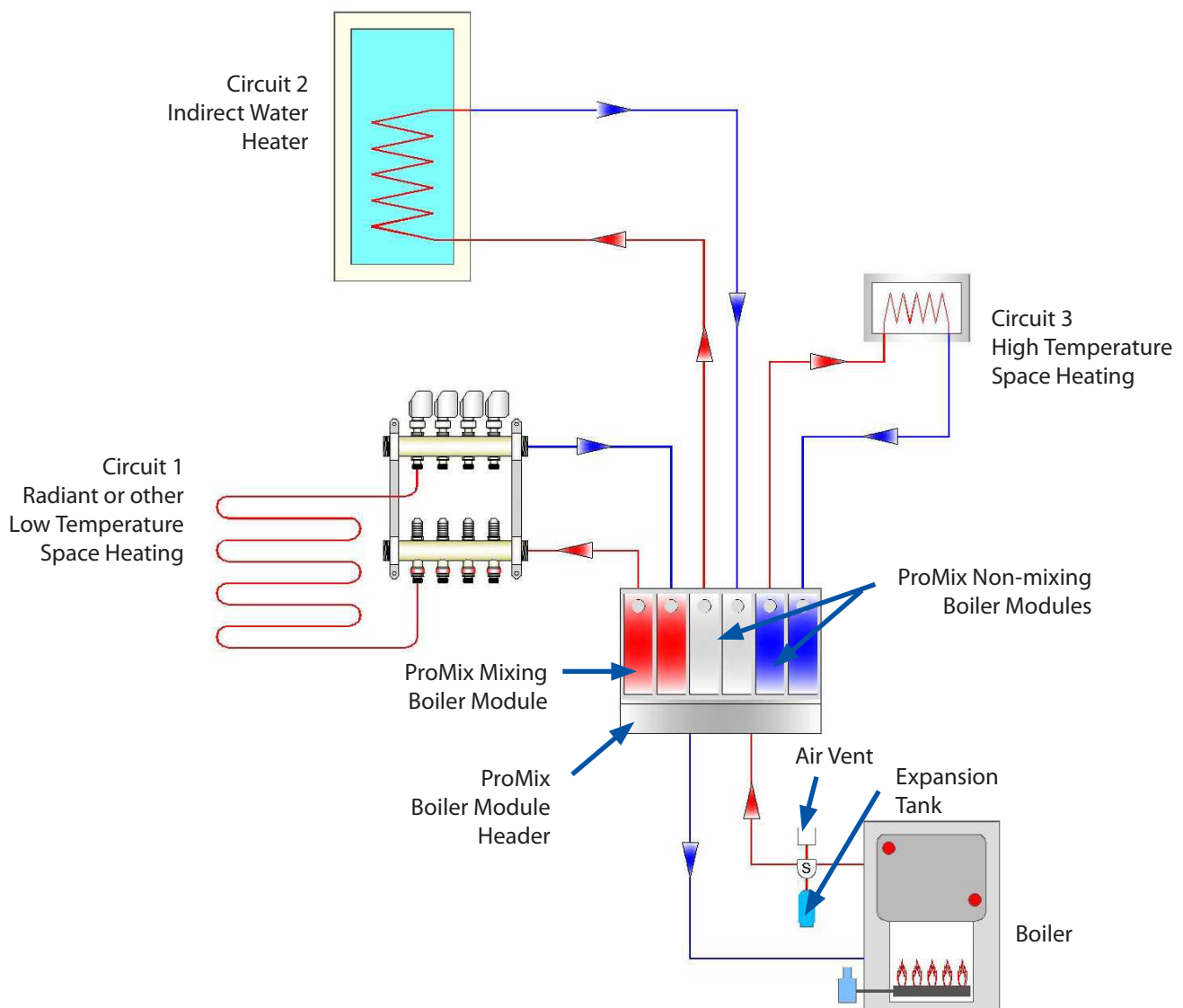

Fig 3 - Mixed Boiler Modules as primary water circulators

Boiler loop layout #2: Boiler module and primary/ secondary pump circuit

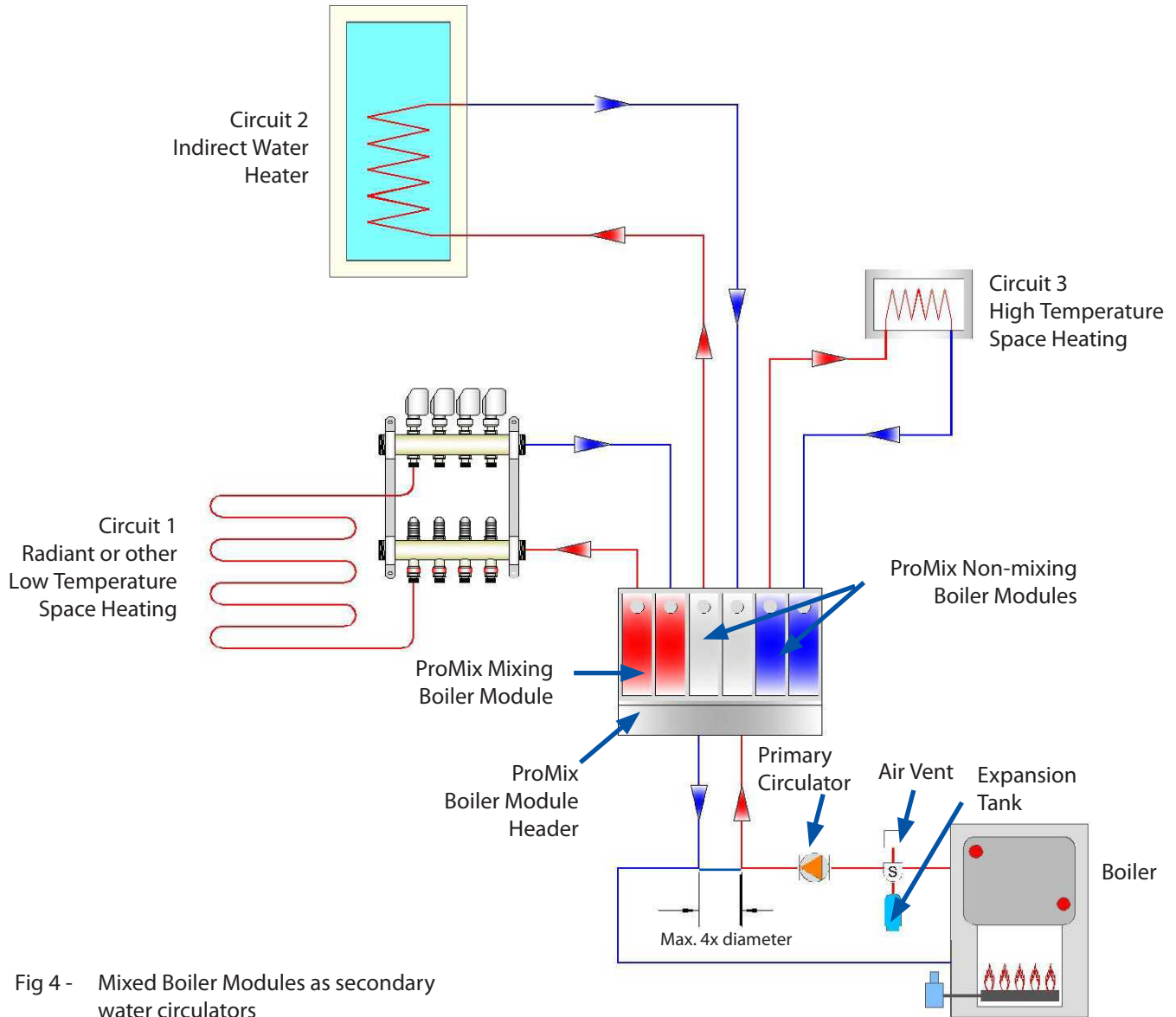

Fig 4 - Mixed Boiler Modules as secondary water circulators

Caution

Installations must be in accordance with applicable codes as well as with applicable parts of the boiler manufacturer's installation instructions.

ProMix Boiler Module Application

AquaHeat ProMix Boiler Modules are pre-assembled modules to facilitate the installation of mixed circuit heating solutions for small to large central boiler projects. Through a high degree of integration these compact modules require little space in the mechanical room and thus can be integrated into any project. Two Modules are available for deployment:

ProMix Non-Mixing Boiler Module (P/N 450085)

Return thermometer, Isolation valve



Header Connections

By-Pass Valve

Supply thermometer/Isolation valve/check valve

Circuit pump (not part of the delivery)

Features

- Ball valves with return handle with integrated thermometer 32 - 248°F in red (supply) and blue (return)
- Gravity flowstop, can be suppressed by turning the valve handle to the 45° position
- Dip holder for remote-sensing probe of return and supply
- 11/4" NPT female threads on the outlets
- 11/2" BSP male threads on the inlet matching boiler header or multi-purpose connection set, see accessories
- Bypass pressure relief valve replaceable without draining the system
- Compact insulation box out of EPP (Expanded Polypropylene) avoiding excessive heat loss
- Insulation with patented double-folded snap-seam connection – quick open and shut

Note: ProMix non-mixing boiler modules are delivered without circulator pump. It is the installers responsibility to identify and fit the right pump for the application

ProMix Mixing Boiler Module (P/N 450057)

Return thermometer, Isolation valve

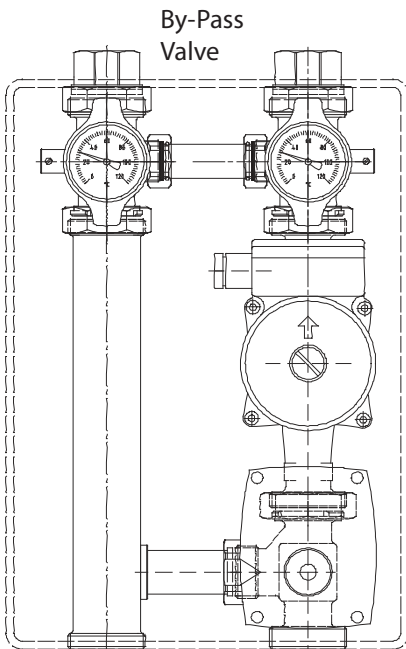

Header Connections

By-Pass Valve

Supply thermometer/Isolation valve/check valve

Circuit pump

3-way mixing valve with actuator

Features

- Ball valves with return handle with integrated thermometer 32 - 248°F in red (supply) and blue (return)
- Gravity flowstop, can be suppressed by turning the valve handle to the 45° position
- Dip holder for remote-sensing probe of return and supply
- 11/4" NPT female threads on the outlets (on the top of the pump module)
- 11/2" BSP male threads on the inlet matching boiler header or multi-purpose connection set, accessories
- 3-way mixing valve, CV-rate 9.28
- Bypass pressure relief valve replaceable without draining down the system
- Compact insulation box out of EPP (Expanded Polypropylene) avoiding excessive heat loss
- Insulation with patented double-folded snap-seam connection – quick open and shut

Note: ProMix mixing boiler modules are delivered without circulator pump. It is the installers responsibility to identify and fit the right pump for the application

Technical Data

ProMix Non-Mixing Boiler Module (#450085)

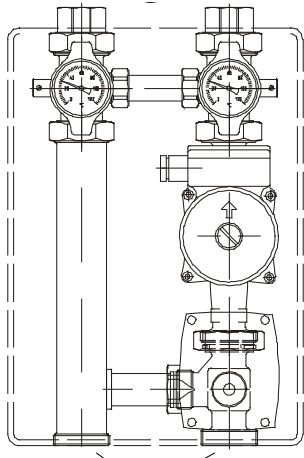
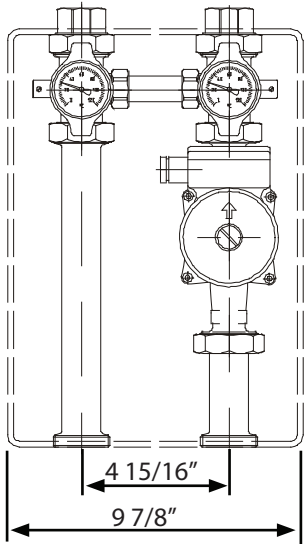

ProMix Mixing Boiler Module (#450057)

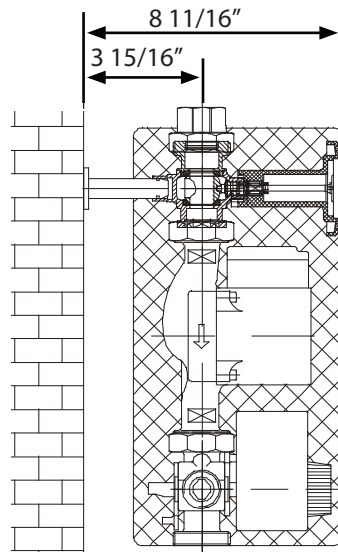
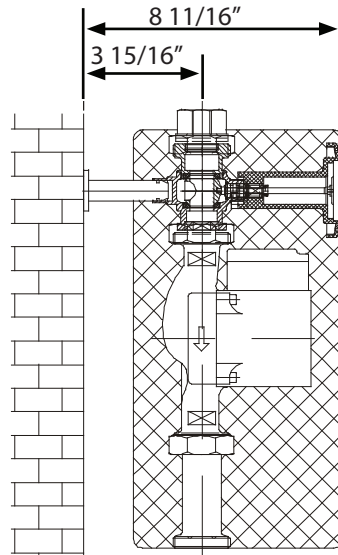

ProMix Boiler Module Type	#450085 Non Mixing Boiler Module	#450057 Mixing Boiler Module
Max. operating temperature	230°F	230°F
Min. operating temperature	-4°F	+59°F
Max. operating pressure	147 psi	147 psi
Max. capacity	85K BTU/h	57K BTU/h
Weight (weight incl. avg. pump weight)	8.5 (~17.0) lbs	11 (~19.0) lbs

* Possibility of condensate formation at media temperature below 20°C. In addition, suitable cooling agents must be used if the media temperature falls below the freezing point of water.

Materials	
Fittings	hot-pressed brass, Ms58
Pipe systems	precision pipes
Heat insulation cladding	EPP – with patented snap seam fitting
Grips	glass fibre-reinforced and temperature-resistant plastic
O-ring seals	EPDM elastomers
Flat seals	AFM 34 or EPDM elastomers
Ball seats	PTFE (Teflon)

Fig 5 - ProMix Boiler Module Dimensions

Selecting the circulator pump

ProMix non-mixing and mixing boiler modules are delivered without circulator pump. It is the installers responsibility to identify and fit the right pump for the application. Suitable pumps are limited to a maximum pressure of 147psi for either modules.

Installation Instructions for AquaHeat ProMix Boiler Modules

1. Unpack and check all units for completeness
2. Install the ProMix bracket set for std US Boiler (#450349) first by marking a horizontal line on the wall where you want the temperature gauges to locate.
4. By aligning the mounting holes of the bracket to the marker on the hole and affix the bracket. If more than one bracket is being used the individual mounting brackets snap into each other with dovetailed ends. Mount all brackets.
5. Remove the rear insulation from the assembled ProMix boiler module and remove the knockouts on the back of the insulation.
6. Slide the insulation panel rears over the posts on the wall mounting brackets.

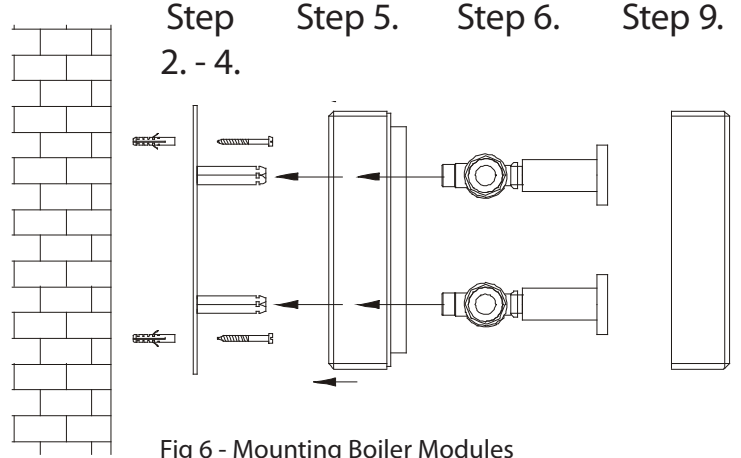

Fig 6 - Mounting Boiler Modules

7. Insert the ProMix boiler module piping into the rear panel so that the ball valve backs rest over the mounting bracket posts. When the boiler module pipes are fully inserted over the posts, retaining clips will snap into place on the posts. Check that all modules are securely fastened on the mounting brackets.
8. Repeat steps 3. through 7. for all ProMix boiler modules
9. Place Insulation cover over the boiler module after connection of all boiler module pipes.

Note: Confirm that the method used to anchor the wall brackets to the wall is adequate to support the weight of the circuit boiler module as well as that of any piping supported by the boiler module system. See Boiler Module weight specifications.

Connect ProMix boiler modules

1. Outlets (top)
ProMix boiler modules can easily be connected to various heating groups. The module outlets are threaded as 1 1/4" NPT. To convert the outlets in stand-alone "pump station" applications use connection sets from ComfortPro's AquaHeat series:



Part #	Connect From (Module)	Connect To
450015	1 1/4" Union	1 1/4" female NPT
450016	1 1/4" Union	1 1/4" female SWT

2. Inlets (boiler side)
In most cases where AquaHeat boiler modules are being used they are connected from the boiler side (inlet) through the ProMix header module.

For applications in which ProMix boiler modules are used without the header, it might become necessary to convert the 1 1/2" BSP union inlets.

ProMix mixing boiler module - 3-way mixing valve motor assembly

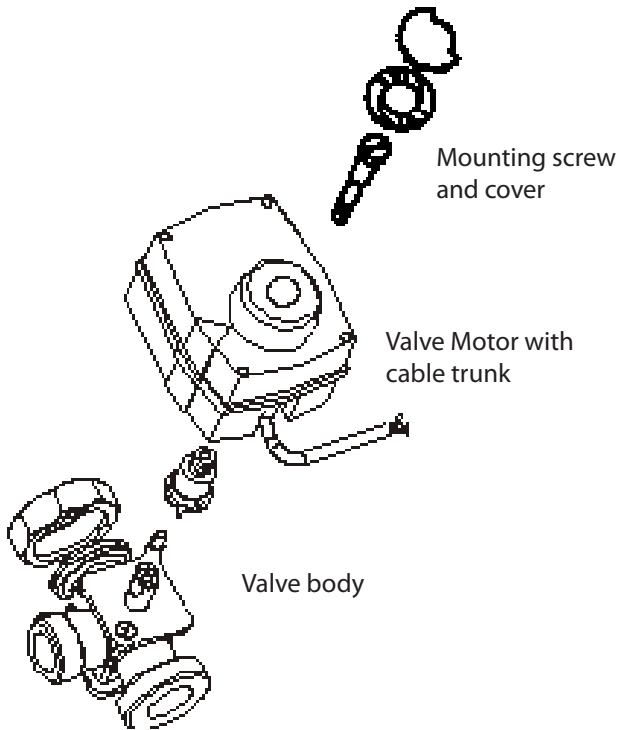

Fig 7 - Mounting/Removal of the Servomotor

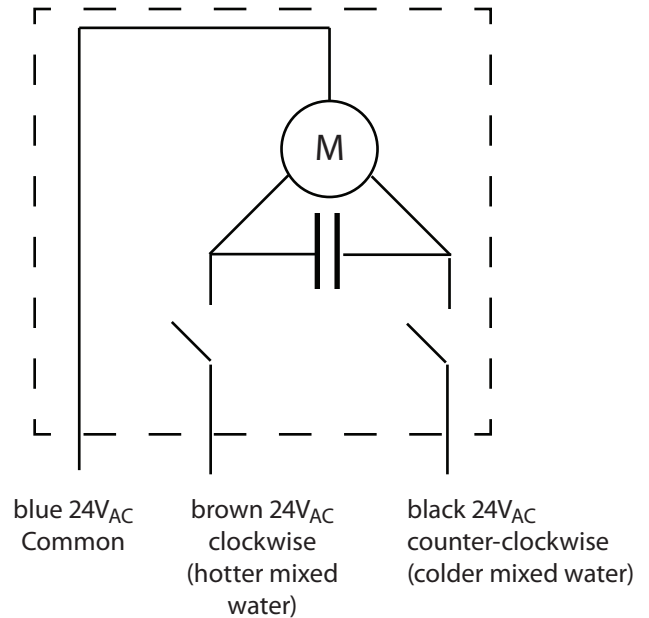

Fig 8 - Wire Harness of the Servomotor

Wiring the ProMix boiler modules

ProMix Boiler Pump

ProMix boiler module pumps are controlled by the control system. With ProZone control systems the pump can be directly connected to the Pro 4 or 6 Zone Master module (see chapter 4) or directly through a 4 - wire ProZone actuator by using the end-switch feature. Wiring must be routed directly to the pump using metallic conduit or other protection as permitted within the regions code. The module insulation can be cut as needed to route the wiring to the pump. For use of the boiler module with insulation make sure to use wire with a 105C rating.

ProMix Mixing Boiler Valve

ProMix mixing boiler module comes with a motorized 3 - way mixing valve. The wiring of the 3 - wire motor is shown in schematic above. This floating point type mixing valve should be used with a setpoint controller like Aqua-Heat set point controller #30150.

Switching Supply and Return sides of ProMix Boiler Modules

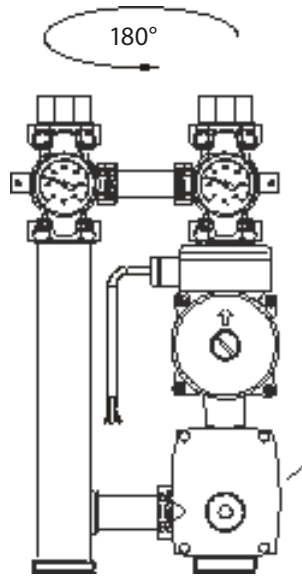

Step 1.
Remove servomotor A (see Fig. 7 Page 11 Mounting/Removal of the servomotor)
Rotate complete assembly by 180°

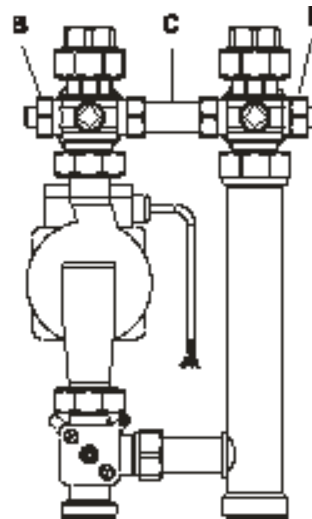

Step 2.
Remove immersion sleeves B as well as the overflow valve (connecting pipe) C.

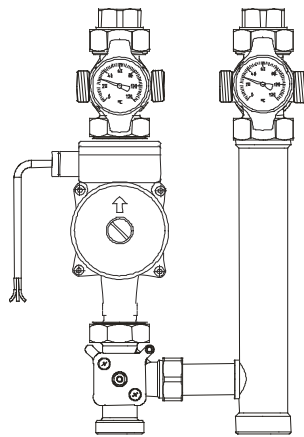
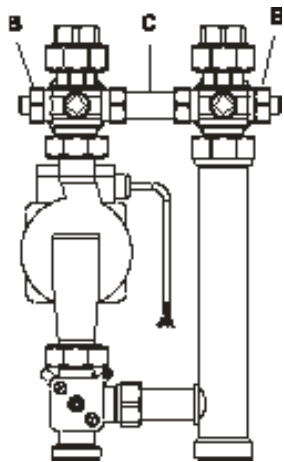

Step 3.
Unscrew pump screw connection D as well as return ball valve screw connection E.
Rotate pump with flow ball valve and return ball valve by 180°. Firmly tighten screw connections D and E again.

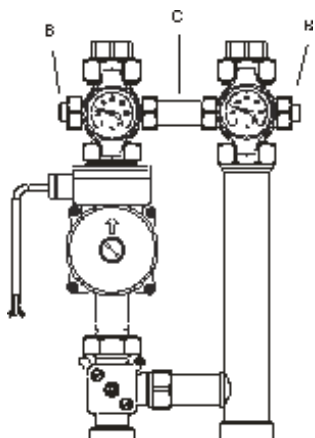

Step 4.
Re-mount immersion sleeves B as well as the overflow valve (connecting pipe) C. Important: Pay attention to the direction of flow specified on the overflow valve.

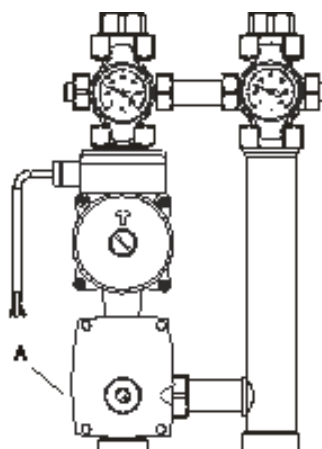

Step 5.
Mount servomotor A (see Fig. 7 Page 11- Mounting/Removal of the servomotor). Ensure correct direction of rotation.

ProMix Header Modules

AquaHeat header modules are primarily used in mixed circuit heating system designs. ProMix header distribute high temperature water from the boiler or cascaded boiler group to various applications in mixed temperature heating projects. Flat-seal flanges with 1 1/2" BSP union nuts allow for easy connection to the boiler modules. AquaHeat ProMix header modules come as two circuit and three circuit designs. The headers are delivered with a heating insulation cladding made of EPP with patented snap seam fitting which also serves as the transport protection.

ProMix header modules come as 2 (#450027) or 3 (#450028) boiler module units

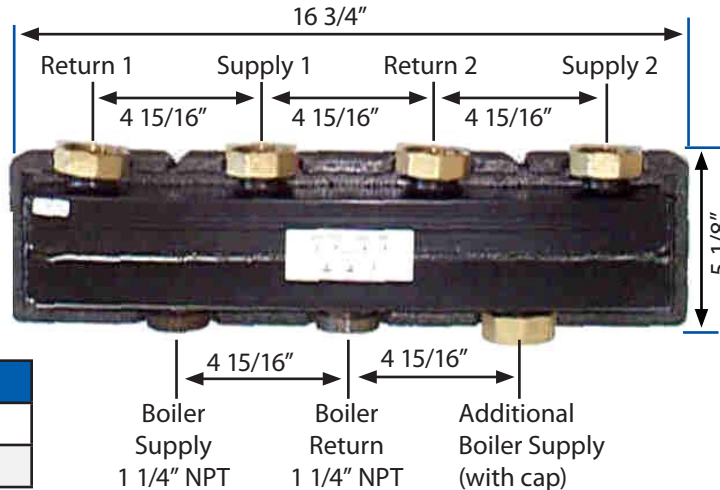

ProMix Header	Weight
2 Module Header	12.0 lbs
3 Module Header	18.0 lbs

Installation of ProMix Header modules

After mounting the two or three ProMix boiler modules for use in a mixed temperature circuit application, we connect them with the ProMix header.

1. Unpack and inspect the ProMix 2 (3) module header
2. Connect all union connections of the ProMix boiler module bottoms to the top union connectors using the flat gaskets provided after the ProMix boiler modules have been mounted to the wall.
3. Connect the boiler supply and return lines to the bottom of the header module. The header provides two return outlets for left or right mounted boilers. Don't forget to keep the cap on the unused boiler return.

Use of multiple Header/Boiler Modules

If the project on hand requires multiple Boiler/header modules they can be combined in the primary boiler loop in one of two ways. Care has to be taken that the boiler capacity and circulator is matched with the applications demand.

Serial Header Combination

By connecting the return of header I with the supply of header II. Water not diverted through the header is pumped into header II. The return of header II is connected to the boiler return and boiler supply to header I. See fig 1. This combination is suitable for applications with only low temperature hydronic floor pump modules. In all other cases we recommend the parallel header combination.

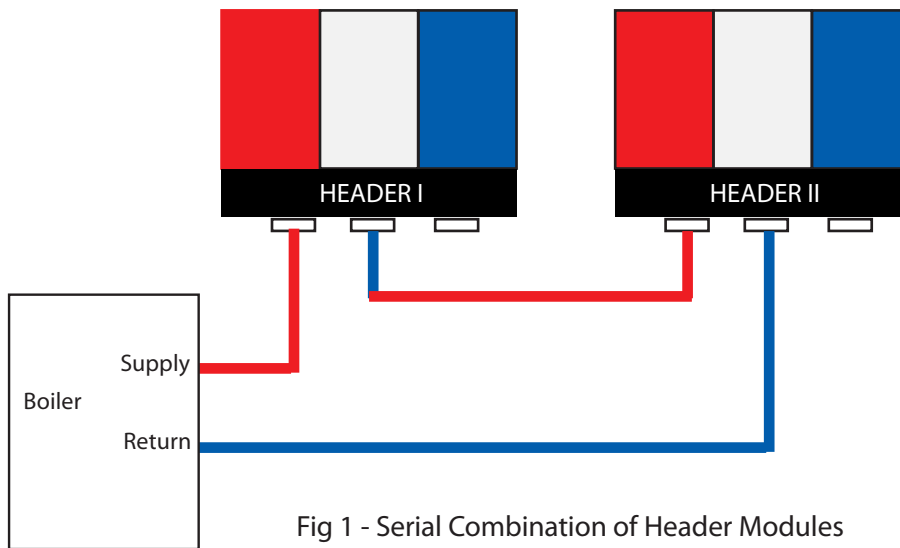

Fig 1 - Serial Combination of Header Modules

Parallel Header Combination

A second way of combining two or more headers is by using a boiler bus system or Y-connection (2 header) like in fig 2. Use this combination method when mixed high and low temperature circuits are used.

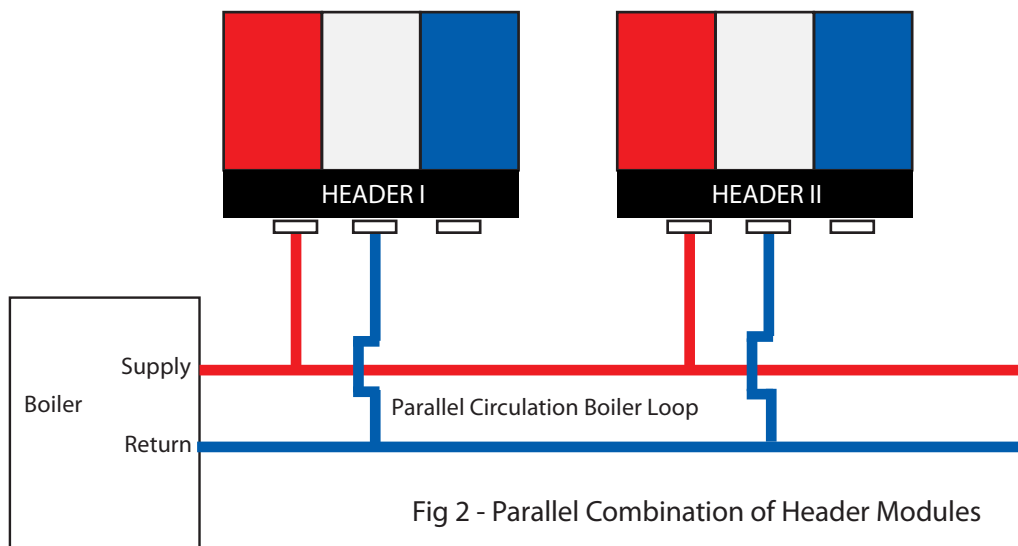

Fig 2 - Parallel Combination of Header Modules

AquaHeat





ComfortPro Systems LLC
 Phone: 1-800-968-8905
www.comfortprosystems.com

Radiant Heating and Snowmelting products

www.ComfortProSystems.com

ComfortProSystems
AquaHeat

CPS_AQH0033____2011