

Product
Selection
QuietAir System

A better
approach to
cooling systems

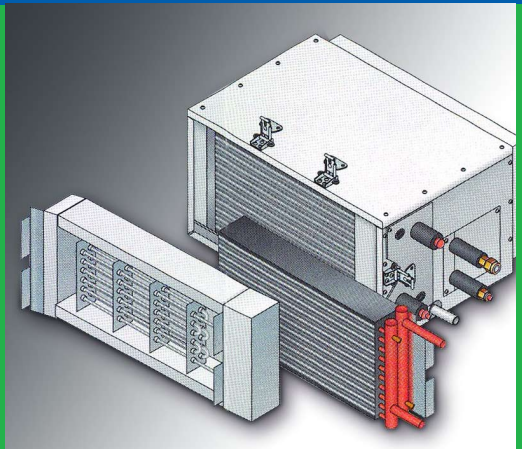

QuietAir Air Distribution Systems from ComfortPro Systems

QuietAir delivers conditioned air at high speeds up to 2000 FPM (flow velocity in Feet Per Minute) to various zones through 2" or 3" flexible duct. It employs insulated flexible return and supply air ducts (both R4.2 and R8.0 depending on the need) to provide great flexibility so that contractors can easily lay out system components such as outdoor unit, return air grill, indoor unit, air diffuser, and many others.

In new buildings, QuietAir saves noticeable room and construction cost. In retrofit work to historic buildings, QuietAir integrates with existing architecture and aesthetics.

Always, QuietAir reduces installation complexity and saves installation time and cost, decreases repair frequency... in the meantime system performance is well maintained.

Key Features of QuietAir Air Distribution Technology

- Flexible design of air distribution systems enables and simplifies various installations especially in an attic
- Insulated 3" flexible duct delivers conditioned air quickly while operating quietly and smoothly
- Uniform air driving force easily pushes conditioned air through every 3" flexible duct
- The ADC (Air Distribution Center) box absorbs noise transmitted from blower/coil modules and trunk line
- Air mixing by aspiration eliminates hot or cold spots.
- 2 and 3 inch outlets can be installed in the ceiling, floor, or walls.
- The return air kit includes all return air components including transitions, filter grille, and flexible duct. The return air filter grille makes changing filters easy with its hinged filter access
- All components assemble with aluminum foil tape (UL181), and duct straps for easy installation.

System Components in this Catalog

ComfortPro Systems has created system packages which create an easy way of ordering a system based on only a couple of key sizing parameters. These kits are found on pages 4 - 10 of this price list.

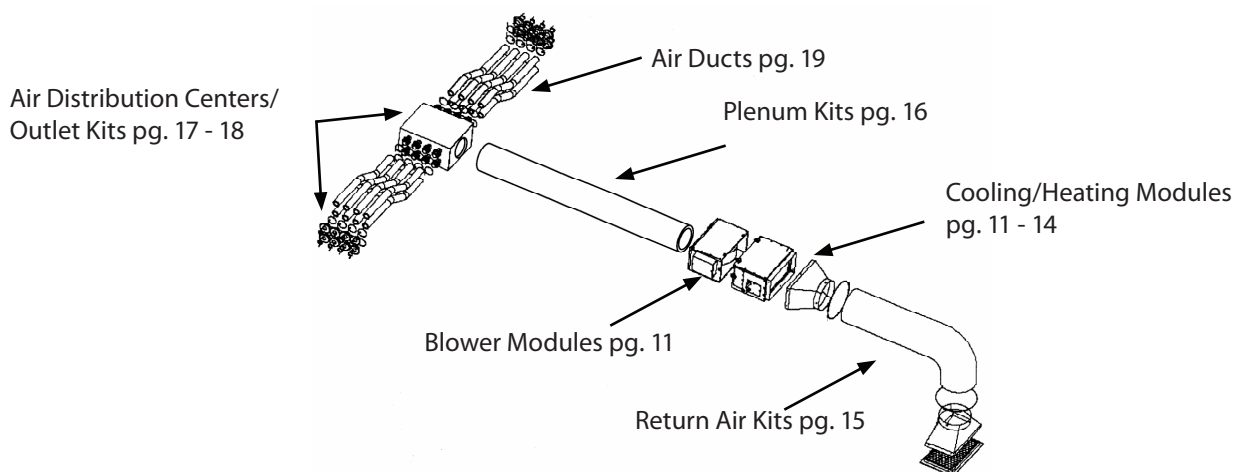

QuietAir System Packages

1.5 - 2 Ton Non-Split Distribution System w/ 2" & 3" Ducts	4
2.5 Ton Non-Split Distribution System w/ 2" & 3" Ducts	5
3 Ton Non-Split Distribution System w/ 2" & 3" Ducts	6
2.5 - 3 Ton Split Distribution System w/ 2" & 3" Ducts	7
4 Ton Split Distribution System w/ 2" & 3" Ducts	8
5 Ton Non-Split Distribution System w/ 2" & 3" Ducts	9
5 Ton Split Distribution System w/ 2" & 3" Ducts	10

QuietAir System Components

Blower/Cooling Coil Modules	11
Product Nomenclature	12
Outline Dimensions	13
Shipping Dimensions/Weights	14
Coil Modules & Supplemental Heating Units	15
Cooling & Heat Pump Expansion Valves	16
Return Air Kits	17
Secondary Drain Pans	17
Plenum Kits	18
Air Distribution Center/Outlet Kits	19-20
Outlet Kits	21
Ducts	21
Duct Flange Adapt	22
Replacement Parts	22

1.5-2 Ton Non-Split System with 2" Duct, R8

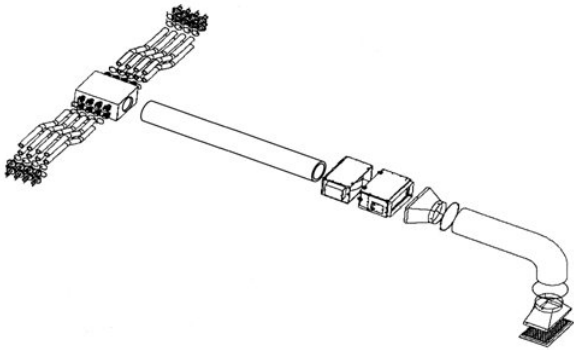

Select between R22 and R410A compatible Heat Pump Expansion Valve Packages

Options/Accessories/Extras

Qty	Part #	Description
1	241032	2" Oak Outlet Kit, 4 Pcs/Pack
1	2420323	3" Oak Outlet Kit, 2 Pcs/Pack

Item	Qty	Part #	Description
1	1	900066	2, 5 Ton R-8 Acoustical Return Air Kit
2	1	242041	VC2-1824-HX 24MBH DX Cooling Coil Module Requires TXV Kit
3	1	242040	VB2-1824-MM2 400-700 CFM Multi-Position Blwr Module 208/230/1Ph
4	1	242053/242054	CBBIVE2GA R22 or CBBIZE R410A TXV For 1.5-2.5 Ton
5	1	2420468	11"x 12' Flexible Duct (Fiberglass R8-Al. Core, 1 Pcs/Box)
6	1	2420082	2T,Airbox Kit, Non-Split Option System
7	16	2420308	2" X 25' Fiberglass Flexduct R8 Alumicore,1 Pc
8	1	243029	2T Secondary Drain Pan (not shown)
			QA2T2R22PKG Total Package 2" 1.5 & 2 Ton System with R22 TXV
			QA2T2R410PKG Total Package 2", 1.5 & 2 Ton System with R410A TXV

1.5-2 Ton Non-Split System with 3" Duct, R8

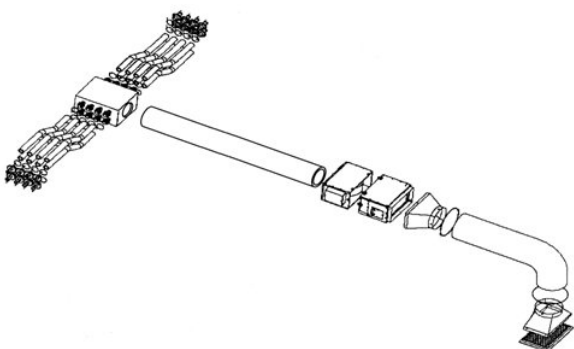

Select between R22 and R410A compatible Heat Pump Expansion Valve Packages

Options/Accessories/Extras

Qty	Part #	Description
1	241032	2" Oak Outlet Kit, 4 Pcs/Pack
1	2420323	3" Oak Outlet Kit, 2 Pcs/Pack

Item	Qty	Part #	Description
1	1	900066	2, 5 Ton R-8 Acoustical Return Air Kit
2	1	242041	VC2-1824-HX 24MBH DX Cooling Coil Module Requires TXV Kit
3	1	242040	VB2-1824-MM2 400-700 CFM Multi-Position Blwr Module 208/230/1Ph
4	1	242053/242054	CBBIVE2GA R22 or CBBIZE R410A TXV For 1.5-2.5 Ton
5	1	2420468	11"x 12' Flexible Duct (Fiberglass R8-Al. Core, 1 Pcs/Box)
6	1	2420083	2T,Airbox Kit, Non-Split Option System
7	12	2430308	3" X 25' Fiberglass Flexduct R8 Alumicore,1 Pc
8	1	243029	2T Secondary Drain Pan (not shown)
			QA2T3R22PKG Total Package 3" 1.5 & 2 Ton System with R22 TXV
			QA2T3R410PKG Total Package 3" 1.5 & 2 Ton System with R410A TXV

2.5 Ton Non-Split System with 2" Duct, R8

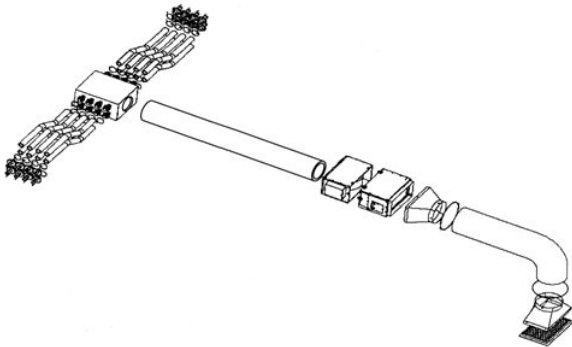

Select between R22 and R410A compatible Heat Pump Expansion Valve Packages

Options/Accessories/Extras

Qty	Part #	Description
1	241032	2" Oak Outlet Kit, 4 Pcs/Pack
1	2420323	3" Oak Outlet Kit, 2 Pcs/Pack

Item	Qty	Part #	Description
1	1	900067	3,4 Ton R-8 Acoustical Return Air Kit
2	1	302041	VC2-2430-MX 30MBH DX Cooling Coil Module Requires TXV Kit
3	1	362040	VB2-3036-MM2 750-1000 CFM Multi-Position Blwr Module 208/230/1Ph
4	1	362053/362054	CBBIVE3GA R22/CBBIZE3GA R410A TXV For 2.5 - 3 Ton
5	1	2420468	11"x 12' Flexible Duct (Fiberglass R8-Al. Core, 1 Pcs/Box)
6	1	3020192	2.5T,Airbox Kit, Non-Split Option System
7	20	2420308	2" X 25' Fiberglass Flexduct R8 Alumicore,1 Pc
8	1	362015	3T and 4T Secondary Drain Pan (not shown)
			QA2.5T2R22PKG Total Package 2", 2.5 Ton System w/ R22 TXV
			QA2.5T2R410PKG Total Package 2", 2.5 Ton System w/ R410A TXV

2.5 Ton Non-Split System with 3" Duct, R8

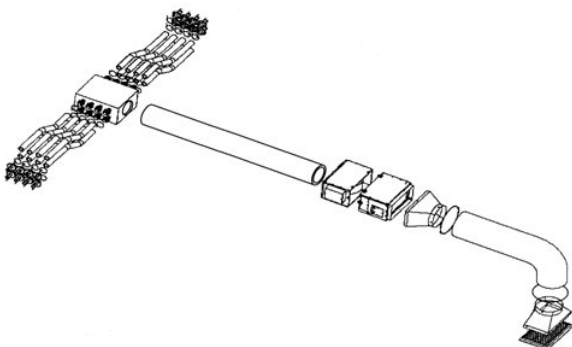

Select between R22 and R410A compatible Heat Pump Expansion Valve Packages

Options/Accessories/Extras

Qty	Part #	Description
1	241032	2" Oak Outlet Kit, 4 Pcs/Pack
1	2420323	3" Oak Outlet Kit, 2 Pcs/Pack

Item	Qty	Part #	Description
1	1	900067	3,4 Ton R-8 Acoustical Return Air Kit
2	1	302041	VC2-2430-MX 30MBH DX Cooling Coil Module Requires TXV Kit
3	1	362040	VB2-3036-MM2 750-1000 CFM Multi-Position Blwr Module 208/230/1Ph
4	1	362053/362054	CBBIVE3GA R22/CBBIZE3GA R410A TXV For 2.5 - 3 Ton
5	1	2420468	11"x 12' Flexible Duct (Fiberglass R8-Al. Core, 1 Pcs/Box)
6	1	3020193	2.5T,Airbox Kit, Non-Split Option System
7	15	24303038	3" X 25' Fiberglass Flexduct R8 Alumicore,1 Pc
8	1	362015	3T and 4T Secondary Drain Pan (not shown)
			QA2.5T3R22PKG Total Package 3", 2.5 Ton System w/ R22 TXV
			QA2.5T3R410PKG Total Package 3", 2.5 Ton System w/ R410A TXV

3 Ton Non-Split System with 2" Duct, R8

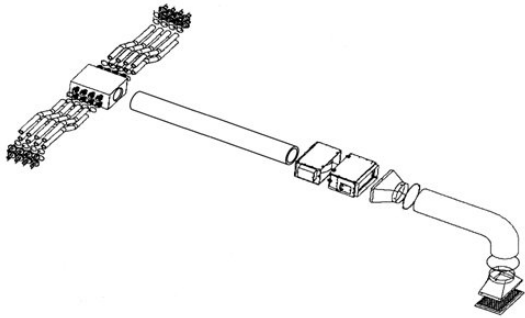

Select between R22 and R410A compatible Heat Pump Expansion Valve Packages

Options/Accessories/Extras

Qty	Part #	Description
1	241032	2" Oak Outlet Kit, 4 Pcs/Pack
1	2420323	3" Oak Outlet Kit, 2 Pcs/Pack

Item	Qty	Part #	Description
1	1	900067	3,4 Ton R-8 Acoustical Return Air Kit
2	1	500327	VC3-3036-MX 36MBH DX Cooling Coil Module Requires TXV Kit
3	1	362040	VB2-3036-MM2 750-1000 CFM Multi-Position Blwr Module 208/230/1Ph
4	1	362053/362054	CBBIVE3GA R22/CBBIZE3GA R410A TXV For 2.5 - 3 Ton
5	1	2420468	11"x 12' Flexible Duct (Fiberglass R8-Al. Core, 1 Pcs/Box)
6	1	3620192	3T,Airbox Kit, Non-Split Option System
7	24	2420308	2" X 25' Fiberglass Flexduct R8 Alumicore,1 Pc
8	1	362015	3T and 4T Secondary Drain Pan (not shown)
		QA3T2R22PKG	Total Package 2", 3 Ton System w/ R22 TXV
		QA3T2R410PKG	Total Package 2", 3 Ton System w/ R410A TXV

3 Ton Non-Split System with 3" Duct, R8

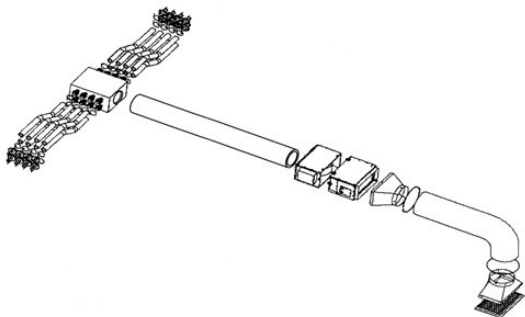

Select between R22 and R410A compatible Heat Pump Expansion Valve Packages

Options/Accessories/Extras

Qty	Part #	Description
1	241032	2" Oak Outlet Kit, 4 Pcs/Pack
1	2420323	3" Oak Outlet Kit, 2 Pcs/Pack

Item	Qty	Part #	Description
1	1	900067	3,4 Ton R-8 Acoustical Return Air Kit
2	1	500327	VC3-3036-MX 36MBH DX Cooling Coil Module Requires TXV Kit
3	1	362040	VB2-3036-MM2 750-1000 CFM Multi-Position Blwr Module 208/230/1Ph
4	1	362053/362054	CBBIVE3GA R22/CBBIZE3GA R410A TXV For 2.5 - 3 Ton
5	1	2420468	11"x 12' Flexible Duct (Fiberglass R8-Al. Core, 1 Pcs/Box)
6	1	3620193	3T,Airbox Kit, Non-Split Option System
7	18	24303038	3" X 25' Fiberglass Flexduct R8 Alumicore,1 Pc
8	1	362015	3T and 4T Secondary Drain Pan (not shown)
		QA3T3R22PKG	Total Package 3", 3 Ton System w/ R22 TXV
		QA3T3R410PKG	Total Package 3", 3 Ton System w/ R410A TXV

2.5-3 Ton Split System with 2" Duct, R8

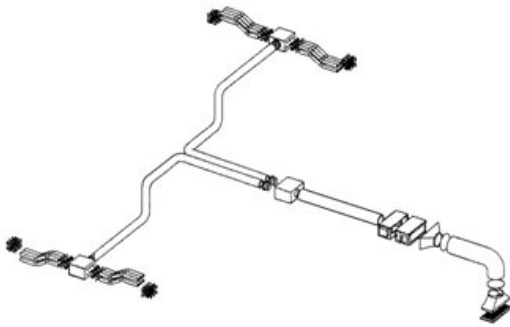

Select between R22 and R410A compatible Heat Pump Expansion Valve Packages

Options/Accessories/Extras

Qty	Part #	Description
1	241032	2" Oak Outlet Kit, 4 Pcs/Pack
1	2420323	3" Oak Outlet Kit, 2 Pcs/Pack

Item	Qty	Part #	Description
1	1	900067	3,4 Ton R-8 Acoustical Return Air Kit
2	1	500327	VC3-3036-MX 36MBH DX Cooling Coil Module Requires TXV Kit
3	1	362040	VB2-3036-MM2 750-1000 CFM Multi-Position Blwr Module 208/230/1Ph
4	1	362053/362054	CBBIVE3GA R22/CBBIZE3GA R410A TXV For 2.5 - 3 Ton
5	1	2420468	11"x 12' Flexible Duct (Fiberglass R8-Al. Core, 1 Pcs/Box)
6	1	362016	3 & 5 Ton Split Box w/ 8" Round Connections
7	2	3620098	8" x 25' Flexible Duct (Fiberglass R8-Al. Core, 1Pcs/Box)
8	2	3620112	3T,Secondary Airbox Kit, Split Option System
9	24	2420308	2" X 25' Fiberglass Flexduct R8 Alumicore,1 Pc
10	1	362015	3T and 4T Secondary Drain Pan (not shown)
			QA3T2SR22PKG Total Package 2", 3 Ton Split - System w/ R22 TXV
			QA3T2SR410PKG Total Package 2", 3 Ton Split - System w/ R410A TXV

2.5-3 Ton Split System with 3" Duct, R8

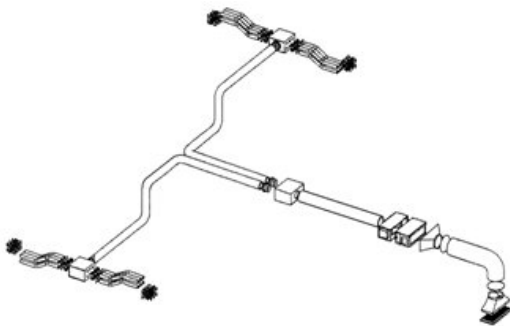

Select between R22 and R410A compatible Heat Pump Expansion Valve Packages

Options/Accessories/Extras

Qty	Part #	Description
1	241032	2" Oak Outlet Kit, 4 Pcs/Pack
1	2420323	3" Oak Outlet Kit, 2 Pcs/Pack

Item	Qty	Part #	Description
1	1	900067	3,4 Ton R-8 Acoustical Return Air Kit
2	1	500327	VC3-3036-MX 36MBH DX Cooling Coil Module Requires TXV Kit
3	1	362040	VB2-3036-MM2 750-1000 CFM Multi-Position Blwr Module 208/230/1Ph
4	1	362053/362054	CBBIVE3GA R22/CBBIZE3GA R410A TXV For 2.5 - 3 Ton
5	1	2420468	11"x 12' Flexible Duct (Fiberglass R8-Al. Core, 1 Pcs/Box)
6	1	362016	3 & 5 Ton Split Box w/ 8" Round Connections
7	2	3620098	8" x 25' Flexible Duct (Fiberglass R8-Al. Core, 1 Pcs/Box)
8	2	3620113	3T,Secondary Airbox Kit, Split Option System
9	18	2430308	3" X 25' Fiberglass Flexduct R8 Alumicore, 1 Pc/box
10	1	362015	3T and 4T Secondary Drain Pan (not shown)
			QA3T3SR22PKG Total Package 3", 3 Ton Split - System w/ R22 TXV
			QA3T3SR410PKG Total Package 3", 3 Ton Split - System w/ R410A TXV

4 Ton Split System with 2" Duct, R8

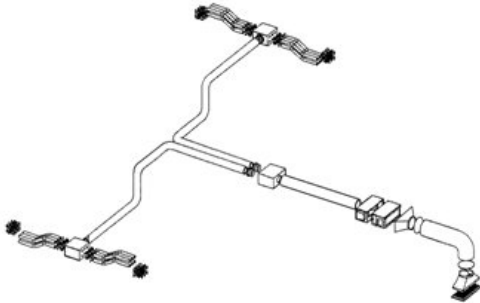

Select between R22 and R410A compatible Heat Pump Expansion Valve Packages

Options/Accessories/Extras

Qty	Part #	Description
1	241032	2" Oak Outlet Kit, 4 Pcs/Pack
1	2420323	3" Oak Outlet Kit, 2 Pcs/Pack

Item	Qty	Part #	Description
1	1	900067	3,4 Ton R-8 Acoustical Return Air Kit
2	1	500328	VC3-4248-MX 48MBH DX Cooling Coil Module Requires TXV Kit
3	1	482040	VB2-3048-MM2 750-1300 CFM Multi-Position Blwr Module 208/230/1Ph
4	1	482053/482054	CBBIVE4GA R22/CBBIZE4GA R410A TXV For 4 Ton
5	1	2420468	11"x 12' Flexible Duct (Fiberglass R8-Al. Core, 1 Pcs/Box)
6	1	482016	4 Ton Split Box w/ 8" Round Connections
7	2	4820098	9" x 25' Flexible Duct (Fiberglass R8-Al. Core, 1Pcs/Box)
8	2	4820012	4T,Secondary Airbox Kit, Split Option System
9	32	2420308	2" X 25' Fiberglass Flexduct R8 Alumicore,1 Pc
10	1	362015	3T and 4T Secondary Drain Pan (not shown)
			QA4T2SR22PKG Total Package 2", 4 Ton Split - System w/ R22 TXV
			QA4T2SR410PKG Total Package 2", 4 Ton Split - System w/ R410A TXV

4 Ton Split System with 3" Duct, R8

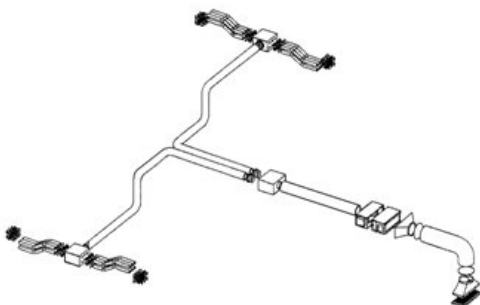

Select between R22 and R410A compatible Heat Pump Expansion Valve Packages

Options/Accessories/Extras

Qty	Part #	Description
1	241032	2" Oak Outlet Kit, 4 Pcs/Pack
1	2420323	3" Oak Outlet Kit, 2 Pcs/Pack

Item	Qty	Part #	Description
1	1	900067	3,4 Ton R-8 Acoustical Return Air Kit
2	1	500328	VC3-4248-MX 48MBH DX Cooling Coil Module Requires TXV Kit
3	1	482040	VB2-3048-MM2 750-1300 CFM Multi-Position Blwr Module 208/230/1Ph
4	1	482053/482054	CBBIVE4GA R22/CBBIZE4GA R410A TXV For 4 Ton
5	1	2420468	11"x 12' Flexible Duct (Fiberglass R8-Al. Core, 1 Pcs/Box)
6	1	482016	4 Ton Split Box w/ 9" Round Connections
7	2	4820098	9" x 25' Flexible Duct (Fiberglass R8-Al. Core, 1Pcs/Box)
8	2	4820013	4T,Secondary Airbox Kit, Split Option System
9	24	2430308	3" X 25' Fiberglass Flexduct R8 Alumicore,1 Pc
10	1	362015	3T and 4T Secondary Drain Pan (not shown)
			QA4T3SR22PKG Total Package 3", 4 Ton Split - System w/ R22 TXV
			QA4T3SR410PKG Total Package 3", 4 Ton Split - System w/ R410A TXV

5 Ton Non-Split System with 2" Duct, R8

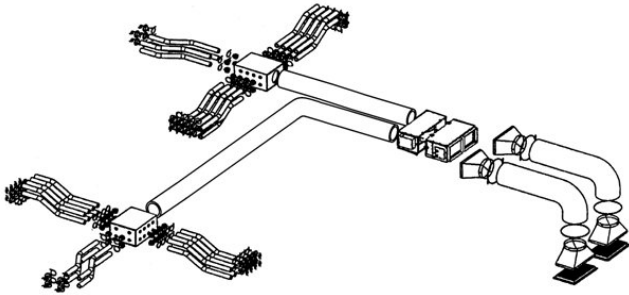

Select between R22 and R410A compatible Heat Pump Expansion Valve Packages

Options/Accessories/Extras

Qty	Part #	Description
1	241032	2" Oak Outlet Kit, 4 Pcs/Pack
1	2420323	3" Oak Outlet Kit, 2 Pcs/Pack

Item	Qty	Part #	Description
1	2	900066	2, 5 Ton R-8 Acoustical Return Air Kit
2	1	602041	VC2-4860-MX 60MBH DX Cooling Coil Module Requires TXV Kit
3	1	602040	VB2-4860-MM2 750-1300 CFM Multi-Position Blwr Module 208/230/1Ph
4	1	602053/602054	CBBIVE5GA R22/CBBIZE5GA R410A TXV For 5 Ton
5	2	2420468	11"x 12' Flexible Duct (Fiberglass R8-Al. Core, 1 Pcs/Box)
6	2	6020012	5T, Airbox Kit, Non-Split Option System
7	40	2420308	2" X 25' Fiberglass Flexduct R8 Alumicore, 1 Pc/box
8	1	602003	5T Secondary Drain Pan (not shown)
		QA5T2R22PKG	Total Package 2", 5 Ton System w/ R22 TXV
		QA5T2R410PKG	Total Package 2", 5 Ton System w/ R410A TXV

5 Ton Non-Split System with 3" Duct, R8

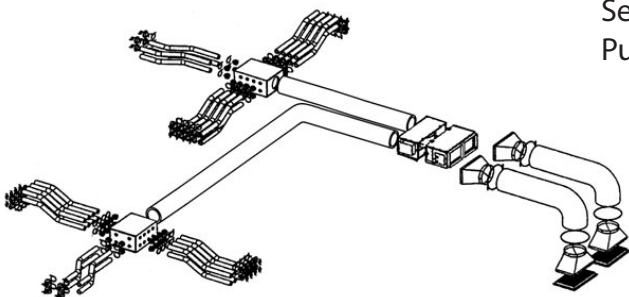

Select between R22 and R410A compatible Heat Pump Expansion Valve Packages

Options/Accessories/Extras

Qty	Part #	Description
1	241032	2" Oak Outlet Kit, 4 Pcs/Pack
1	2420323	3" Oak Outlet Kit, 2 Pcs/Pack

Item	Qty	Part #	Description
1	2	900066	2, 5 Ton R-8 Acoustical Return Air Kit
2	1	602041	VC2-4860-MX 60MBH DX Cooling Coil Module Requires TXV Kit
3	1	602040	VB2-4860-MM2 750-1300 CFM Multi-Position Blwr Module 208/230/1Ph
4	1	602053/602054	CBBIVE5GA R22/CBBIZE5GA R410A TXV For 5 Ton
5	2	2420468	11"x 12' Flexible Duct (Fiberglass R8-Al. Core, 1 Pcs/Box)
6	2	6020013	5T, Airbox Kit, Non-Split Option System
7	30	2430308	3" X 25' Fiberglass Flexduct R8 Alumicore, 1 Pc/box
8	1	602003	5T Secondary Drain Pan (not shown)
		QA5T3R22PKG	Total Package 3", 5 Ton System w/ R22 TXV
		QA5T3R410PKG	Total Package 3", 5 Ton System w/ R410A TXV

5 Ton Split-System with 2" Duct, R8

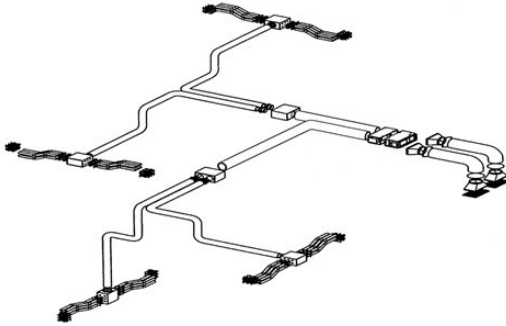

Select between R22 and R410A compatible Heat Pump Expansion Valve Packages

Options/Accessories/Extras

Qty	Part #	Description
1	241032	2" Oak Outlet Kit, 4 Pcs/Pack
1	2420323	3" Oak Outlet Kit, 2 Pcs/Pack

Item	Qty	Part #	Description
1	2	900066	2, 5 Ton R-8 Acoustical Return Air Kit
2	1	602041	VC2-4860-MX 60MBH DX Cooling Coil Module Requires TXV Kit
3	1	602040	VB2-4860-MM2 1200-1800 CFM Multipoise Blwr Module 208/230/1Ph
4	1	602053/602054	CBBIVE5GA R22/CBBIZE5GA R410A TXV For 4 Ton
5	2	2420468	11"x 12' Flexible Duct (Fiberglass R8-Al. Core, 1 Pcs/Box)
6	2	362016	3,5 Ton Split Box w/ 8" Round Connections
7	4	3620098	8" x 25' Flexible Duct (Fiberglass R8-Al. Core, 1Pcs/Box)
8	4	6020042	5T,Secondary Airbox Kit, Split Option System
9	40	2420308	2" X 25' Fiberglass Flexduct R8 Alumicore,1 Pc
10	1	602003	5T Secondary Drain Pan (not shown)
			QA5T2SR22PKG Total Package 2", 5 Ton Split-System w/ R22 TXV
			QA5T2SR410PKG Total Package 2", 5 Ton Split-System w/ R410A TXV

5 Ton Split-System with 3" Duct R8

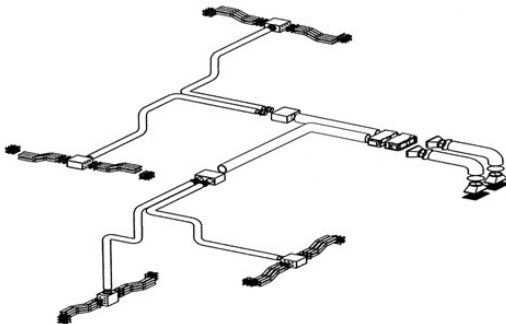

Select between R22 and R410A compatible Heat Pump Expansion Valve Packages

Options/Accessories/Extras

Qty	Part #	Description
1	241032	2" Oak Outlet Kit, 4 Pcs/Pack
1	2420323	3" Oak Outlet Kit, 2 Pcs/Pack

Item	Qty	Part #	Description
1	2	900066	2, 5 Ton R-8 Acoustical Return Air Kit
2	1	602041	VC2-4860-MX 60MBH DX Cooling Coil Module Requires TXV Kit
3	1	602040	VB2-4860-MM2 1200-1800 CFM Multipoise Blwr Module 208/230/1Ph
4	1	602053/602054	CBBIVE5GA R22/CBBIZE5GA R410A TXV For 4 Ton
5	2	2420468	11"x 12' Flexible Duct (Fiberglass R8-Al. Core, 1 Pcs/Box)
6	2	362016	3,5 Ton Split Box w/ 8" Round Connections
7	4	3620098	8" x 25' Flexible Duct (Fiberglass R8-Al. Core, 1Pcs/Box)
8	4	6020043	5T,Secondary Airbox Kit, Split Option System
9	30	24303038	3" X 25' Fiberglass Flexduct R8 Alumicore,1 Pc
10	1	602003	5T Secondary Drain Pan (not shown)
			QA5T3SR22PKG Total Package 3", 5 Ton Split-System w/ R22 TXV
			QA5T3SR410PKG Total Package 3", 5 Ton Split-System w/ R410A TXV

Blower Module



Part #	Description
242040	2-Ton VB2-1824-MM2
362040	3-Ton VB2-3036-MM2
900181	2.5-4-Ton VB2-3048-MM2
602040	5-Ton VB2-4860-MM2

DX Cooling Coil Module without Expansion valve

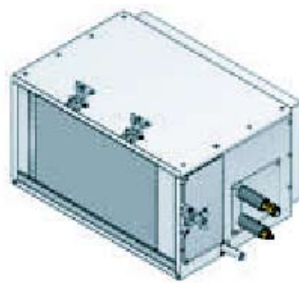

Part #	Description
242041	2-Ton VC2-1824-MX, Cooling Capacity 24,500 (nominal Btu/h)
302041	2.5-Ton VC2-2430-MX, Cooling Capacity 30,000 (nominal Btu/h)
500327	3-Ton VC2-3036-MX, Cooling Capacity 36,500 (nominal Btu/h)
482041	4-Ton VC2-4248-MX, Cooling Capacity 49,000 (nominal Btu/h)
602041	5-Ton VC2-4860-MX, Cooling Capacity 61,000 (nominal Btu/h)

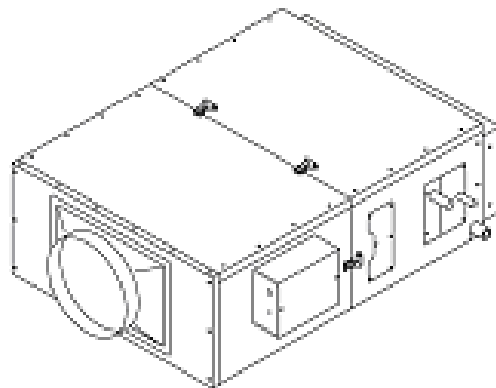

Tonnage	Recommended Circuit Breaker Size
1.5 - 2.0	2 Pole 15A
2.5 - 3.0	2 Pole 15A
3.5 - 4.0	2 Pole 15A
4.5 - 5.0	2 Pole 15A

Table 2: Unit Specifications - Blower Module / DX Cooling Coil Module

Tonnage (tons)	Nominal capacity		Rated Airflow (CFM)	Power Input (V/PH/HZ)	Motor Ratings			Liquid Line OD (in)	Suction Line ND (in)	Recommended Outdoor Unit (Ton)
	Cooling (BTU/h)	HP Heating (BTU/h)			Speed (RPM)	HP	Amps			
1.5 - 2.0	24,000	24,500	600	208-230/1/60	1625	2/5	1.99	1/2	5/8	1.5 - 2.0
2.5 - 3.0	36,000	36,500	1000	208-230/1/60	1500	1.0	4.71	1/2	3/4	2.5 - 3.0
3.5 - 4.0	48,000	49,000	1300	208-230/1/60	1700	1.0	4.71	1/2	3/4	3.5 - 4.0
4.0 - 5.0	60,000	61,000	1520	208-230/1/60	1700	2x 3/5	5.32	1/2	1 1/8	4.0 - 5.0

Note: 5.0 Ton is a dual blower module

Tonnage	Blower Modules	Cooling Coil Modules
1.5 - 2.0	242040 / VB2-1824-MM2	242041 / VC2-1824-MX
2.0 - 2.5	302040 / VB2-3036-MM2	302041 / VC2-3036-MX
2.5 - 3.0	362040 / VB2-3036-MM2	362041 / VC2-3036-MX
3.5 - 4.0	482040 / VB2-4248-MM2	482041 / VC2-4248-MX
4.0 - 5.0	602040 / VB2-4860-MM2	602041 / VC2-4860-MX

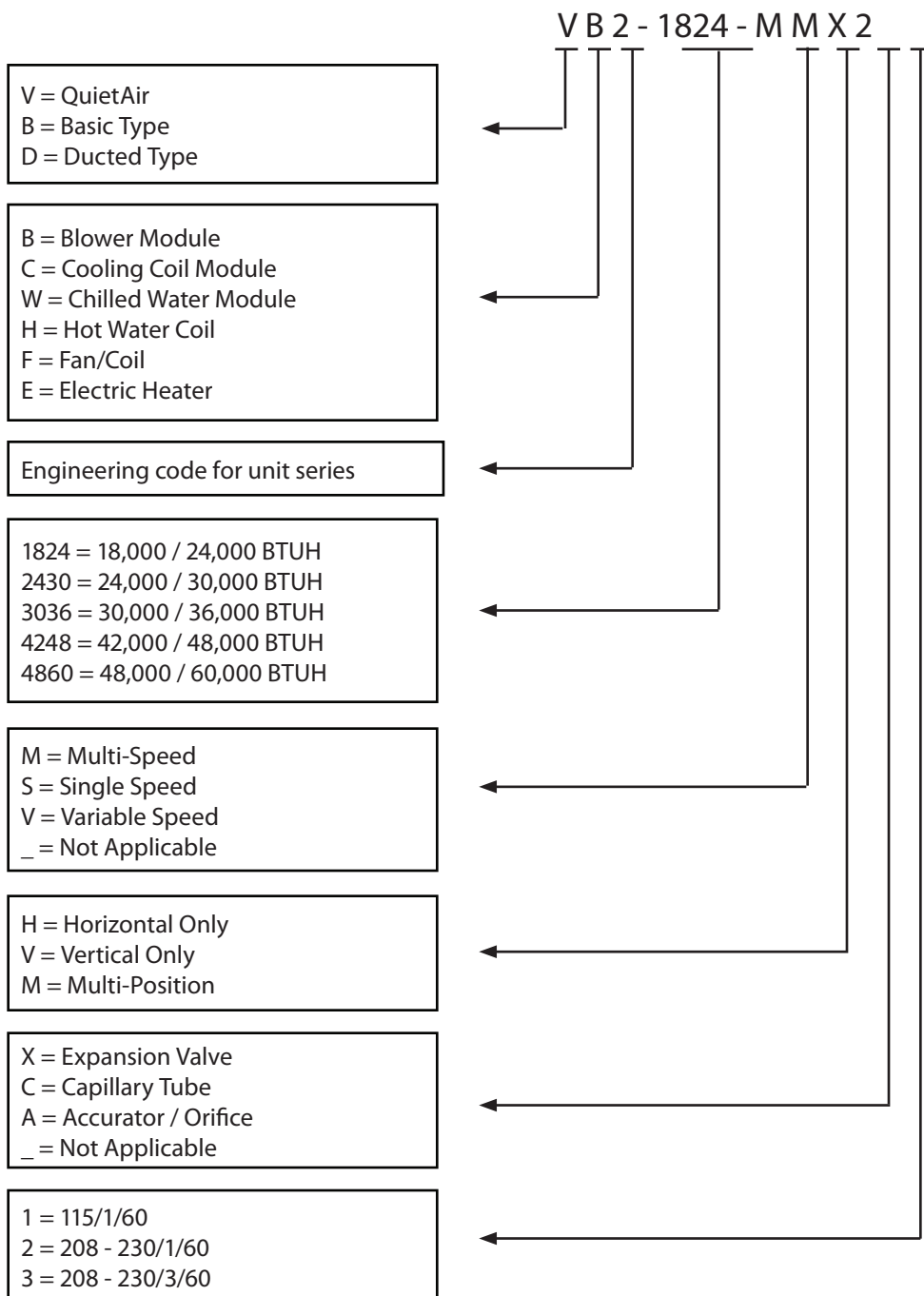

1. Both Modules are Latched Together

Table 10:
Outline Dimensions* - Front View

Ton	A	B	C	E	F	G	H
1.5 - 2.0	13.2	23.8	11	10.3	28.3	8.2	15.0
2.0 - 2.5	13.2	34.4	11	10.2	38.3	8.2	15.0
2.5 - 3.0	13.2	34.4	11	10.2	38.3	8.2	15.0
3.5 - 4.0	13.2	34.4	11	10.2	38.3	8.2	15.0
4.5 - 5.0	13.2	52.8	11	10.3	57.8	8.2	15.0

* Dimensions for Reference only
* 4.0 - 5.0 Ton has 2 blower openings

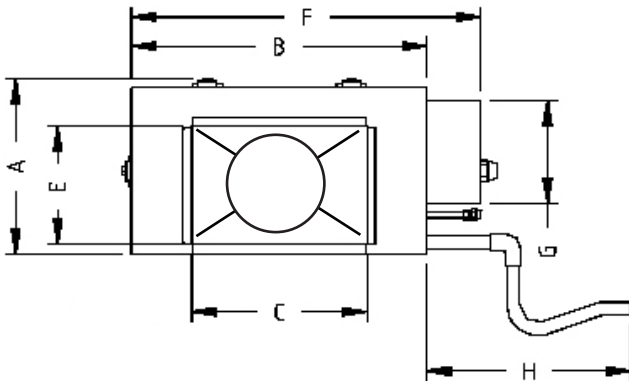

Figure 16: Outline Dimensions - Front View

Table 11:
Outline Dimensions* - Top View

Ton	A	B	C	D
1.5 - 2.0	15.6	44.6	22.2	10.7
2.0 - 2.5	15.6	44.6	32.2	10.7
2.5 - 3.0	15.6	44.6	32.2	10.7
3.5 - 4.0	15.6	44.6	32.2	15.2
4.0 - 5.0	15.6	46.3	52.8	17.5

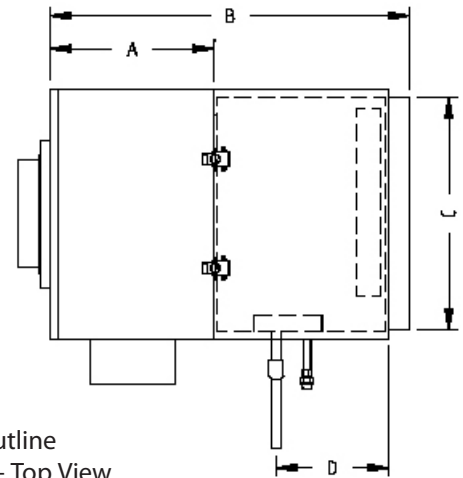

Figure 17: Outline Dimensions - Top View

2. Individual Indoor Module

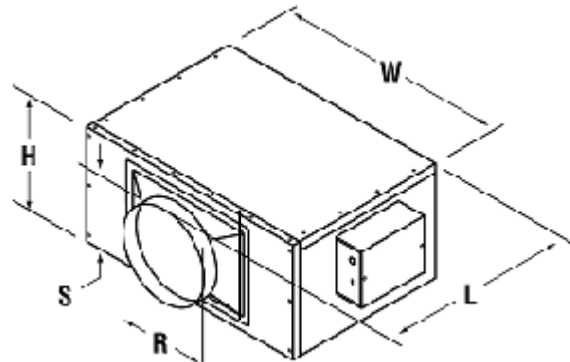

Figure 18: Blower Module Dimensions

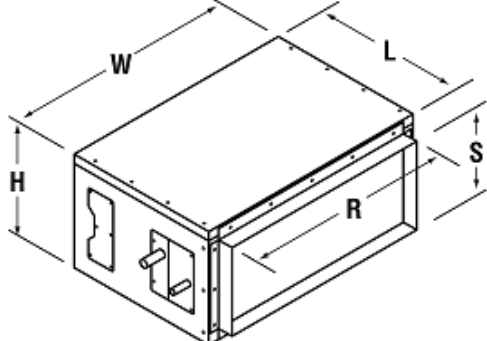

Figure 19: Coil Module Dimensions

Table 12: Blower Module Dimensions

Ton	Part #	Model No.	H	W	L	R	S
1.5 - 2.0	242040	VB2-1824-MM2	13.2	23.8	20.1	11	11
2.5 - 3.0	362040	VB2-3036-MM2	13.2	34.4	20.1	11	11
3.5 - 4.0	482040	VB2-3648-MM2	13.2	34.4	20.1	11	11
4.0 - 5.0	602040*	VB2-4860-MM2	13.2	52.8	21.7	11	11

Note: VB2-4860-MM2 (* Part # 602040) has 2 outlets and two return air connections

Table 13: Coil Module Dimensions

Ton	Part #	Model No.	H	W	L	R	S
1.5 - 2.0	242041	VC2-1824-MX	13.2	23.8	24.6	22.2	11.6
2.5	302041	VC2-1824-MX	13.2	34.4	24.6	32.2	11.6
2.5 - 3.0	362041	VC2-3036-MX	13.2	34.4	24.6	32.2	11.6
3.5 - 4.0	482041	VC2-4860-MX	13.2	34.4	24.6	32.2	11.6
4.0 - 5.0	602041	VC2-4860-MX	13.2	52.8	24.6	49.5	11.6

Note: 4.0 - 5.0 Ton has 2 blower openings

Dimension and Weight of Equipment and Accessories (Packed in Carton Boxes)

Description	Model	Part #	Gross Weight w/ box (lbs)	Packaging	W (in)	L (in)	H (in)	Vol (Cu Ft)
Equipment								
Blower Module	VB2-1824-MM2	242040	61.0	1 per box	20.5	29.5	15.0	5.25
	VB2-3036-MM2	362040	77.0	1 per box	20.5	39.0	15.0	6.94
	VB2-4248-MM2	482040	77.0	1 per box	20.5	39.0	15.0	6.94
	VB2-4860-MM2	602040	112.0	1 per box	20.5	60.0	15.0	10.68
DX Coil Module	VC2-1824-MX	242041	39.0	1 per box	24.5	29.5	15.0	6.27
	VC2-2430-MX	302301	48.0	1 per box	24.5	39.0	15.0	8.29
	VC2-3048-MX	362041	48.0	1 per box	24.5	39.0	15.0	8.29
	VC2-4248-MX	482041	52.0	1 per box	29.5	39.0	15.0	9.99
	VC2-4860-MX	602041	100.0	1 per box	29.5	60.0	15.0	15.36
Chill/Hot Water Coil Module	VW2-0024-H	242042	39.0	1 per box	24.5	29.5	15.0	6.27
	VW2-0036-H	362042	50.0	1 per box	24.5	39.0	15.0	8.29
	VW2-0048-H	482042	53.0	1 per box	24.5	39.0	15.0	8.29
	VW2-0060-H	602042	102.0	1 per box	29.5	60.0	15.0	15.36
Hot Water Coil Kit	VH1-0024-H	241044	14.0	1 per box	12.5	27.5	15.0	1.49
	VH1-0036-H	361044	18.0	1 per box	12.5	38.0	15.0	2.06
	VH1-0048-H	481044	22.0	1 per box	12.5	38.0	15.0	2.06
	VH1-0060-H	601044	29.0	1 per box	12.5	58.0	15.0	3.15
Accessory Kits								
Return Air Kit (2, Ton)		900066	23.0	1 per box	19.0	29.0	17.0	5.42
Return Air Kit (3, 4, 5 Ton)		900067	29.0	1 per box	19.0	41.0	17.0	7.66
ADC W (2Ton) 2"		2420082	12.0	1 per box	14.0	17.0	23.0	4.42
ADC W (2Ton) 3"		2420083	12.0	1 per box	14.0	17.0	23.0	4.42
ADC W (2.5 Ton) 2"		3020192	17.0	1 per box	14.0	17.0	27.0	4.42
ADC W (2.5 Ton) 3"		3020193	17.0	1 per box	14.0	17.0	27.0	4.42
ADC W (3Ton) 2"		3620192	17.0	1 per box	14.0	17.0	23.0	5.27
ADC W (3Ton) 3"		3620193	17.0	1 per box	14.0	17.0	23.0	5.27
SADC W (2.5 & 3Ton) 2"		3620112	11.0	1 per box	14.0	17.0	20.0	3.74
SADC W (2.5 & 3Ton) 3"		3620113	11.0	1 per box	14.0	17.0	20.0	3.74
SADC W (4Ton) 2"		4820012	12.0	1 per box	14.0	17.0	23.0	4.42
SADC W (4Ton) 3"		4820013	12.0	1 per box	14.0	17.0	23.0	4.42
SADC W (5Ton, 4 SADC) 2"		6020012	13.0	1 per box	14.0	17.0	27.0	3.74
SADC W (5Ton, 4 SADC) 3"		6020013	13.0	1 per box	14.0	17.0	27.0	3.74
SADC W (5Ton NS, 2 SADC) 2"		6020042	15.0	1 per box	14.0	17.0	20.0	5.27
SADC W (5Ton NS, 2 SADC) 3"		6020043	15.0	1 per box	14.0	17.0	20.0	5.27
Split Plenum (2.5, 3, 5 -Ton, 8")		362016	11.0	1 per box	14.0	17.0	23.0	4.42
Split Plenum (4-Ton, 9")		482016	11.0	1 per box	14.0	17.0	27.0	4.52
Main Plenum-11" (R8.0)		2420468	27.0	1 per box	48.0	50.0	3.0	4.17
Plastic Outlet Kit 2" (4 Pack)		241010	1.5	Packed in plastic bag	8.0	10.0	5.0	0.23
Oak Outlet Kit 2" (4 Pack)		241032	2.2	Packed in plastic bag	9.0	11.0	5.0	0.34
Plastic Outlet Kit 2" (4 Pack)		2420103	1.5	Packed in plastic bag	8.0	10.0	5.0	0.23
Oak Outlet Kit 3" (2 Pack)		2420323	2.2	Packed in plastic bag	9.0	11.0	5.0	0.34

Chilled/ Hot Water Coil Module

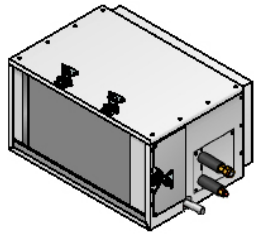

Part #	Description	Cooling Capacity (Btu/h)	Heating Capacity (BTU/h)
242042	2-Ton VW2-0024-M	24,400	50,700
362042	3-Ton VW2-0036-M	35,900	77,100
482042	4-Ton VW2-0048-M	47,200	85,100
602042	5-Ton VW2-0060-M	54,900	95,700

Hot Water Coil Kit

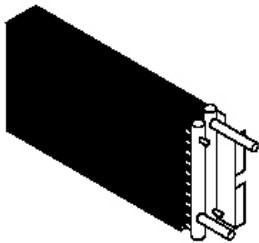

Part #	Description	Heating Capacity (Btu/h)
241044	2-Ton VH1-0024-H	50,700
361044	3-Ton VH1-0036-H	77,100
481044	4-Ton VH1-0048-H	85,100
601044	5-Ton VH1-0060-H	95,700

Electric Heaters

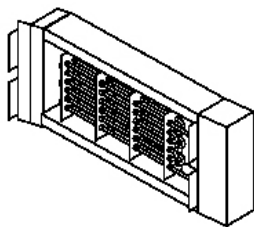

Part #	Description
24104550	5.0 kW Electric Strip Heater for 1.5 - 2.0 Ton Coil Module, VE1-0024-M5
24104575	7.5 kW Electric Strip Heater for 1.5 - 2.0 Ton Coil Module, VE1-0024-M75
24104510	10.0 kW Electric Strip Heater for 1.5 - 2.0 Ton Coil Module, VE1-0024-M10
24204575	7.5 kW Electric Strip Heater for 1.5 - 2.0 Ton Coil Module, VE2-0024-M75
36104575	7.5 kW Electric Strip Heater for 2.5 - 3.0 Ton Coil Module, VE1-0036-M75
36104510	10 kW Electric Strip Heater for 2.5 - 3.0 Ton Coil Module, VE1-0036-M10
36104512	12.5 kW Electric Strip Heater for 2.5 - 3.0 Ton Coil Module, VE1-0036-M125
36204515	15 kW Electric Strip Heater for 2.5 - 3.0 Ton Coil Module, VE2-0036-M15
481045175	17.5 kW Electric Strip Heater for 3.5 - 4 Ton Coil Module, VE1-0048-M175
601045125	12.5 kW Electric Strip Heater for 4 - 5 Ton Coil Module, VE1-0060-M125
60104515	15.0 kW Electric Strip Heater for 4 - 5 Ton Coil Module, VE1-0060-M15
601045175	17.5 kW Electric Strip Heater for 4 - 5 Ton Coil Module, VE1-0060-M175
60104520	20.0 kW Electric Strip Heater for 4 - 5 Ton Coil Module, VE1-0060-M20

Note: 361045 also fits 4 ton cooling module

Accessories

Part #	Description
241045SQ	Electronic Heat Sequencer
241045AR	Electronic Thermal Overload Switch
500212	Circuit Breaker For 12.5 KW Electric Heater (2 REQ'D)

Cooling Coil Expansion Valves

ComfortPro Systems DX Cooling Coil Modules are capable of cooling only or heat pump applications depending on which Expansion Valves are used.

Also models R22 or R410A are available

Part #	Refrigerent used with	Description
068U 2073	R22	TXV22-30 18000-30000 BTU/H TXV (1.5 - 2.5 Ton) Cooling Only
068U 2074	R22	TXV22-42 36000-42000 BTU/H TXV (3.0-3.5 Ton) Cooling Only
068U 2075	R22	TXV22-60 48000-60000 BTU/H TXV (4.0 - 5.0 Ton) Cooling Only
068U 1973	R410A	TXV41-30 18000-30000 BTU/H TXV (1.5 - 2.5 Ton) Cooling Only
068U 1974	R410A	TXV41-42 36000-42000 BTU/H TXV (3.0 - 3.5 Ton) Cooling Only
068U 1975	R410A	TXV41-60 48000-60000 BTU/H TXV (4.0 - 5.0 Ton) Cooling Only

Heat Pump Expansion Valves

Part #	Refrigerent used with	Description
242053	R22	CBBIVE-2-GA 18000-24000 BTU/H (1.5 - 2 Ton) HeatPump TXV
362053	R22	CBBIVE-3-GA 30000-36000 BTU/H (2.5 - 3 Ton) Heat Pump TXV
482053	R22	CBBIVE-4-GA 42000-48000 BTU/H (3.5 - 4 Ton) Heat Pump TXV
602053	R22	CBBIVE-5-GA 48000-60000 BTU/H (4 - 5 Ton) Heat Pump TXV
242054	R410A	CBBIZE-2-GA 18000-24000 BTU/H (1.5 - 2 Ton) HeatPump TXV
362054	R410A	CBBIZE-3-GA 30000-36000 BTU/H (2.5 - 3 Ton) Heat Pump TXV
482054	R410A	CBBIZE-4-GA 42000-48000 BTU/H (3.5 - 4 Ton) Heat Pump TXV
602054	R410A	CBBIZE-5-GA 48000-60000 BTU/H (4 - 5 Ton) Heat Pump TXV

2 & 5-Ton Return Air Kit



Part #	Description	Qty
900066	2 & 5-Ton Return Air Kit includes 1 Filter/Grill, 1 Disposable Filter, 1 Filter/Grill Transition Fitting, 2 Cable Ties, 1 Coil Module Transition Fitting and 1 R-8 Acoustical Alumicore flexible duct (14" OD x 12' long)	1

Note: 5-Ton system requires 2 Return Air Kits

3,4-Ton Return Air Kit



Part #	Description	Qty
900067	3,4-Ton Return Air Kit includes 1 Filter/Grill, 1 Disposable Filter, 1 Filter/Grill Transition Fitting, 2 Cables Ties, 1 Coil Module Transition Fitting and 1 R-8 Acoustical Alumicore flexible duct (16" OD x 12' long)	1

Note: The new kits replace model 241001 and 361001

Vertical Return Air Box

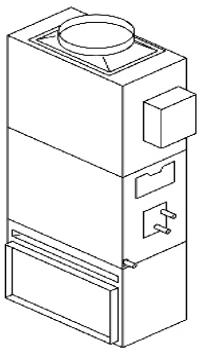

Part #	Description	Qty
242070	2TonVerticalReturnAirBoxw/FilterRackto20x8Duct	1
362070	3TonVerticalReturnAirBoxw/FilterRackto30x8Duct	1
602070	4-5TonVerticalReturnAirBoxw/FilterRackto48x8Duct	1

Part #	Width	Height	Depth
242070	24"	13"	13 1/2"
362070	34 1/2"	13"	13 1/2"
602070	53"	13"	13 1/2"

Secondary Drain Pans

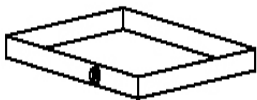

Part #	Description	Qty
242029	2 Ton, Secondary Drain Pan w/ Isolation L 49.5" x W 28.5"	1
243029	2 Ton, Secondary Drain Pan w/ Isolation L 49.5" x W 28.5"	1
362015	3 - 4 Ton, Secondary Drain Pan w/ Isolation L 61.5" x W 37.5"	1
602003	5 Ton, Secondary Drain Pan w/ Isolation L 56" x W 44"	1

2,3,4,5-Ton Main Plenum Kits

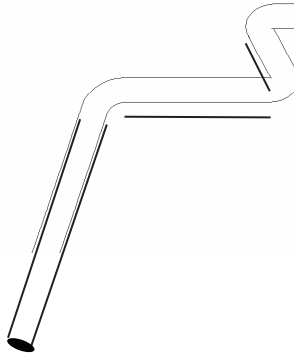

Part #	Description	Qty
2420468	11" Alumicore flexible duct w/ fiberglass, R-8.0, 12' length	1

Part #	Description	Qty
2410178	R 8.0 - 2 Ton Main Plenum 4' Section	1
3610138	R 8.0 - 3,4,5 Ton Main Plenum 4' Section	1

Main Plenum Elbows

Part #	Description	Qty
2410175	R 8.0 - 2 Ton Main Plenum Elbow	1
3610135	R 8.0 - 3,4,5 Ton Main Plenum Elbow	1
900144	Kool Duct Silicone	1
900145	Kool Duct Tiger Connectors 20/pkg	1

Split Plenum Kit

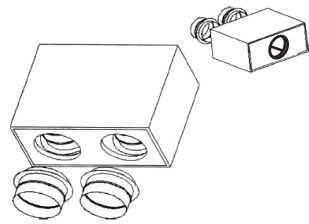

Part #	Description	Qty
362016	3,5-Ton 8" Split Plenum Kit for 11" Round Alumicore includes 1 Split Plenum, 4 Take-off with Tabs (2 for split box, 2 for SADC's), 14" H x 21" W x 26" L	1 per system
482016	4-Ton 9" Split Plenum Kit for 11" Round Alumicore includes 1 Split Plenum, 4 Take-off with Tabs (2 for split box, 2 for SADC's), 14" H x 21" W x 26" L	1 per system

- Take-off with Tabs has flexible tabs which can be bent by hand and allow installation from the outside
- Two of these Take-off with Tabs are connected to Split Plenum, another 2 are put onto 3,4,5-Ton Secondary Air Distribution / Outlet Kit.
- The QuietAir System provides individually packaged 8" flexible round duct at standard length 25'. This 8" round duct connects each pair of Take-off with Tabs (one for Split Plenum, the other for 3,4,5-Ton Secondary Air Distribution / Outlet Kit).

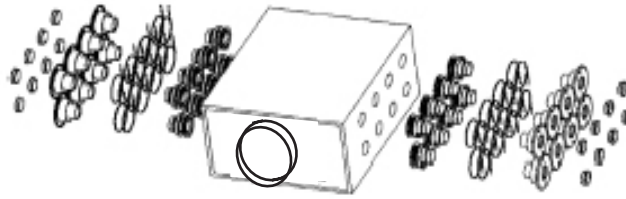

2 Ton-Air Distribution Center/Outlet Kit

Part #	Description	Qty
2420082	2 Ton 2" Air Distribution Box/Outlet Kit (16 outlets 2"), R-8.5 for 11" Rnd/Non-split option, 14" H x 17" W x 23" L	1 per system
2420083	3Ton(Non-SplitOption)3"AirDistributionBox/OutletKit(12outlets 3") R-8.5 for 11" Rnd/Non-split option, 14" H x 17" W x 23" L	1 per system

2.5 Ton-Air Distribution Center/Outlet Kit

Part #	Description	Qty
3020192	2.5TonAirDistributionCenter/OutletKit(20outlets2")R-8.5for 11" Rnd/Non-split option, 14" H x 17" W x 27" L	1 per system
3020193	3Ton(Non-SplitOption)AirDistributionCenter(16outlets3")R-8.5 for 11" Rnd/Non-split option, 14" H x 17" W x 27" L	1 per system

3 Ton-Air Distribution/Outlet Kit (Non-Split Option)

Part #	Description	Qty
3620192	3 Ton (Non-Split Option) Air Distribution Center (24 outlets 2") R-8.5, 14" H x 17" W x 27" L	1 per system
3620193	3 Ton (Non-Split Option) Air Distribution Center (18 outlets 3") R-8.5, 14" H x 17" W x 27" L	1 per system

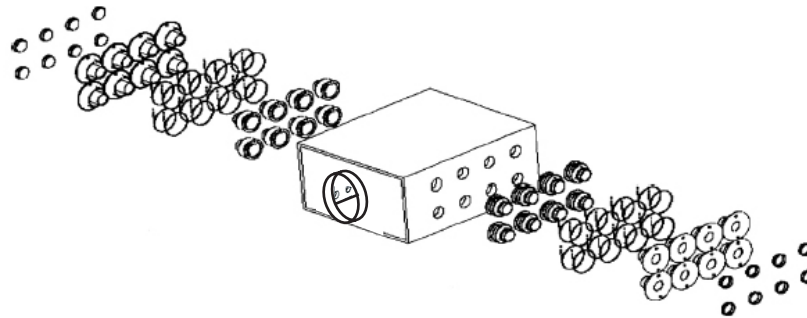

3 Ton-Secondary Air Distribution/Outlet Kit

Part #	Description	Qty
3620112	3 Ton Secondary (Split Option) Air Distribution Center (12 outlets 2") R-8.5, 14" H x 17"W x 20"L	2 per system
3620113	3 Ton Secondary (Split Option) Air Distribution Center (9 outlets 3") R-8.5, 14" H x 17"W x 20"L	2 per system

4 Ton Secondary Air Distribution/Outlet Kit

Part #	Description	Qty
4820012	4Ton2"(11"Rnd/Split-Option)AirDistributionCenter(16x2" outlets) R-8.5	2 per system
4820013	4Ton3"(11"Rnd/Split-Option)AirDistributionCenter(12x3" outlets) R-8.5	2 per system

5 Ton Air Distribution/Outlet Kit (Non-Split Option)

Part #	Description	Qty
6020012	5 Ton (Non-Split Option) Air Distribution Center (20 x 2" outlets) R-8.5, 14" H x 17"W x 27"L	2 per system
6020013	5 Ton (Non-Split Option) Air Distribution Center (16 x 3" outlets) R-8.5, 14" H x 17"W x 27"L	2 per system

20 5 Ton (Split Option) Secondary Air Distribution/Outlet Kit

Part #	Description	Qty
6020042	5 Ton (Split Option) Secondary Air Distribution Center (10 x 2" outlets) R-8.5, 14" H x 17"W x 20"L	4 per system
6020043	5 Ton (Split Option) Secondary Air Distribution Center (8 x 3" outlets) R-8.5, 14" H x 17"W x 20"L	4 per system

(All Tonnage) Outlet Kit (white Plastic and Oak)

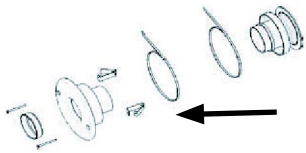

Part #	Description	Qty
241010	2" White Plastic Outlet Kit	(4) pack
2420103	3" White Plastic Outlet Kit	(2) pack
241032	2" Oak Outlet Kit	(4) pack
2420323	3" Oak Outlet Kit	(2) pack
500033	1" x 8.25" to 3" Round Slotted Diffuser	(1)

Note: All Kits include: outlets, two piece take offs, cable ties, mounting clips & screws, and winter shut offs

Duct Accessories



Part #	Description	Qty
241034	2" Flexible Duct Coupling (plastic)	(4) pack
2420343	3" Flexible Duct Coupling (plastic)	(2) pack
3620348	8" Alumicore Coupling w/ Ties & Tape	(1) pack
3620349	9" Alumicore Coupling w/ Ties & Tape	(1) pack
36203411	11" Alumicore Coupling w/ Ties & Tape	(1) pack
36203414	14" Alumicore Coupling w/ Ties & Tape	(1) pack
36203416	16" Alumicore Coupling w/ Ties & Tape	(1) pack
900143	3" Round Adjustable Diffuser Outlets	(2) pack
2410162	2" Outlet Cap	(1)
2410163	3" Outlet Cap	(1)
24201037	3" Wire Mesh Screen	(1)

Insulated Alumicore Flexible Duct



Part #	Description	Qty
2420304	2" x 25' R4.2 50 Micron Round Alumicore flexible duct	(1) per box
2420308	2" x 25' R8.0 50 Micron Round Alumicore flexible duct	(1) per box
2430303	3" x 25' R4.2 Alumicore Rectangular flexible duct	(1) per box
24303038	3" x 25' R8.0 Alumicore Rectangular flexible duct	(1) per box
3620098	8" x 25' R8.0 50 Micron Round Alumicore flexible duct	(1) per box
4820098	9" x 25' R8.0 50 Micron Round Alumicore flexible duct	(1) per box
242046	11" x 25' R4.2 50 Micron Round Alumicore flexible duct	(1) per box
2420468	11" x 25' R8.0 50 Micron Round Alumicore flexible duct	(1) per box
242006	14" x 12' R4.2 50 Micron Round Alumicore flexible duct	(1) per box
362005	16" x 12' R4.2 50 Micron Round Alumicore flexible duct	(1) per box
243006	14" x 12' R4.2 Round Acoustical insulated Duct	(1) per box
363005	16" x 12' R4.2 Round Acoustical insulated Duct	(1) per box
500230	14" x 12' R8 Round Acoustical insulated Duct	(1) per box
500231	16" x 12' R8 Round Acoustical insulated Duct	(1) per box

Note: All ducts are manufactured to UL181 standards
All Alumicore ducts are fiberglass insulated

Blower Flange Adaptor (Round to Square)

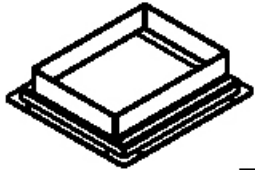

Part #	Description	Qty
242048	2 Ton Blower Flange Adapter (Round to Square)	1
362048	3,4,5 Ton Blower Flange Adapter (Round to Square)	1

Blower Flange Adaptor (Square to Round)

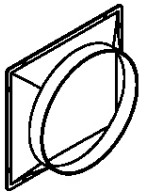

Part #	Description	Qty
362049	2-5 Ton Blower Flange Adapter (11" Round to Square)	1
3610198	3,4,5 Ton Square Take Off	1

Replacement Parts for Return Kits

Part #	Description	Qty
241002	Filter Grille 24" x 14" x 1"	1
361002	Filter Grille 36" x 14" x 1"	1
362003	MERV 7 Replacement Filter 36" x 14" x 1"	1
242003	MERV 7 Replacement Filter 24" x 14" x 1"	1
241004	2.5 Ton Filter Grille Trans Ftg 14"	1
241007	2.5 Ton Coil Mod Trans Ftg 14"	1
361004	3-4 Ton Filter Grille Trans Ftg 16"	1
361006	3-4 Ton Coil Mod Trans Ftg 16"	1

Replacement Parts

Part #	Description
5180315062	2 Ton 230v Motor W/capcitor
6610601109	2 Ton Blower Wheel
5100000007	Plug In Fan Relay Dpst 24 Vac All Units
5100000008	Plug In Fan Relay and terminal base Dpst 24 Vac All Units
5180315061	3 Ton & 5 Ton 230v Motor W/capacitor
6610604007	3.5 Ton Blower Wheel
5180315036	4 Ton 230v Motor W/capacitor
6610604008	4 Ton Blower Wheel
6610604009	10" X 6" Blower Wheel VB2 3, 4, 5 Ton Blowers
6610604012	4-5 Ton Blower Wheel VB1
5160001023	100 VAC Primary 24 VAC Secondary Control Transformer (All Units)
900147	Blower Assy VB2 3048-mm2
5010131055	5 Med X 440 Vac Capacitor
5180001017	5 Speed Motor For VB2 Sub For 5180315061 3 Speed

Warranty

One (1) year parts and labor.



ComfortPro Systems LLC
751 N Rohlwing Rd. Itasca, IL 60143
Phone: 1-800-968-8905
www.comfortprosystems.com

Mini Duct heating and cooling systems

ComfortPro Systems
QuietAir