

ComfortPro suggested specification for high pressure heating and cooling products

1.5 to 5 Tons

QuietAir delivers conditioned air at high speed up to 2000 FPM to various zones through 2” and 3” flexible duct. It employs flexible return and supply air ducts to provide great flexibility so that contractors can easily lay out system components such as outdoor unit, return air, indoor unit, air diffusers, etc. In new buildings, QuietAir saves noticeable room and construction cost. In retrofit work to historic buildings, QuietAir integrates greatly with existing architecture and aesthetics. Most importantly, QuietAir reduces installation complexity and saves installation time and cost, decreases repair frequency while, maintaining system performance.

Key Features of Air Distribution System of QuietAir

- Flexible design of air distribution system enables and simplifies various installation, especially in an attic.
- Patented “Alumicore” flexible ducts increase stability and lowers internal static pressure, for increased airflow.
- Insulated 2” and 3” flexible ducts deliver conditioned air comfortably and quietly.
- Uniform air driving force easily pushes conditioned air through every 2” or 3” flexible duct, evenly.
- 2” and 3” Outlets utilize air aspiration and venturi principles to decrease stratification and increase comfort.
- Diffuser option frees consumer from worry of cool air blow overhead while maintaining a balanced system.
- Various types of outlets provide great flexibility to cover various airflow and thermal zones.
- Simple and convenient return air and filter grill allows easy filter changing and duct cleaning.
- Unit’s critical 14” dimension allows for the modules to be lifted thru the filter grill opening in ceiling to the attic.
- KoolDuct R8.5 phenolic air distribution boxes and connection components make an efficient leak free system.

Key Features of Blower and Coil Modules

- Air moving components are in blower module; thermal components are in coil module.
- Two modules are latched at three sides to seal airflow.
- PSC motor offers maximum efficiency. Resilient ring digests motor vibration.
- Scroll type housing and factory-balanced wheel utilize limited space to provide substantial air driving force.
- Galvanized sheet metal structure is optimized to provide solid mechanism support.
- Long life and respiratory dust-free polyethylene insulation minimizes heat transfer, corrosion and abrasion and reduces noise.
- Full drain pan coverage eliminates condensate splash. Dry drain pan design diminishes risk of ice-climbing to coil.
- Top, front, side access to inside blower components provides great convenience to service
- Motor and motor components slide out form either side of module.
- Outside mounted TEV controls superheat to allow wide matching with various brands of outdoor units.
- Sound thermodynamic performance brings great cooling, heating and airflow comfort with high SEER and HSPF at no extra cost.

Specification of QuietAir-AC and HP Units

Tonnage	Nominal Capacity		Rated Airflow	Power Input	Motor-Rated			Liquid Line Dia.	Suction Line Dia.	Recommended Outdoor Unit
	Cooling	Heating			Speed	HP	Amps			
(Ton)	(Btu/h)	(Btu/h)	(CFM)	(V/PH/Hz)	(RPM)	(HP)	(A)	(Inch)	(Inch)	(Ton)
1 ½ - 2	24,000	24,500	600	208-230/1/60	1625	2/5	1.99	1/2	5/8	1 ½ - 2
2 ½ - 3	36,000	36,500	1000	208-230/1/60	1500	1.0	4.71	1/2	3/4	2 ½ - 3
3 ½ - 4	48,000	49,000	1300	208-230/1/60	1700	1.0	4.71	1/2	3/4	3 ½ - 4
4 - 5	60,000	61,000	1520	208-230/1/60	1700	2x3/5	5.32	1/2	1 1/8	4 – 5

Dimensions of Indoor Modules

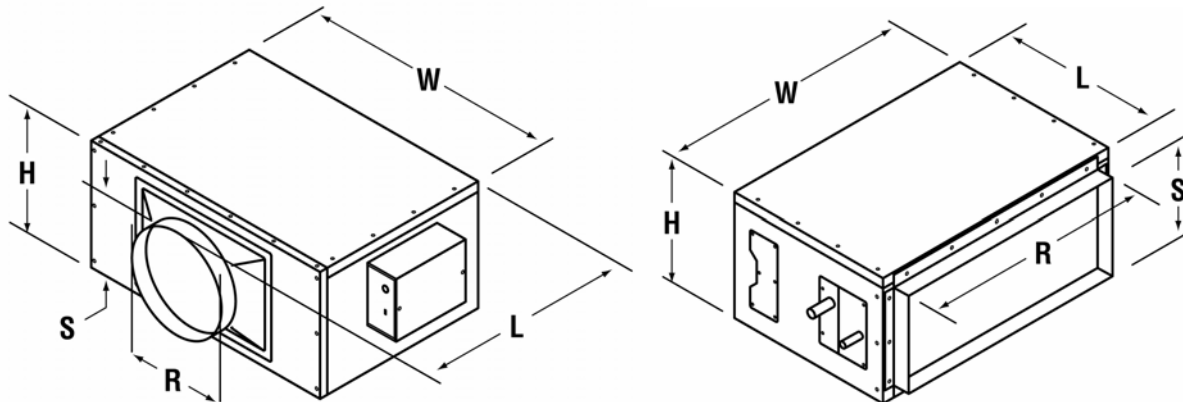

Blower Module

Model No.	H	W	L	R
VB2-1824-MM2	13.2	23.8	20.1	11
VB2-3048-MM2	13.2	34.4	20.1	11
VB2-4860-MM2	13.2	52.8	21.7	11

Coil Module

Model No.	H	W	L	R	S
VC2-1824-MX	13.2	23.8	24.6	22.2	11.6
VC2-3036-MX	13.2	34.4	24.6	32.2	11.6
VC2-4248-MX	13.2	34.4	24.6	32.2	11.6
VC2-4860-MX	13.2	52.8	24.6	49.5	11.6

Remarks: All dimensions in inches. VB2-4860-MM2 has 2 outlets and two return air connections.

Table 9-DIMENSIONS OF ADC, SADC, SPLIT PLENUM:

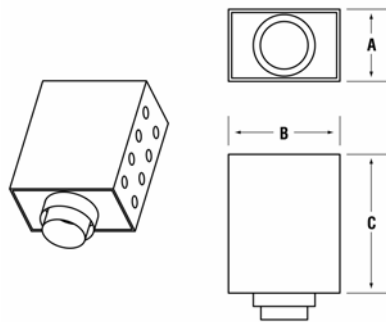

PART NO.	NAME	A (in)	B (in)	C (in)	# of 2" Outlets	# of 3" Outlets
242-0082 or 3	ADC-2 TON	14	17	23	16	12
302-0192 or 3	ADC-2.5 TON	14	17	27	20	15
362-0192 or 3	ADC-3 TON	14	17	27	24	18
602-0042 or 3	ADC-5 TON	14	17	27	2@ 20	2@ 15
362-0112 or 3	SADC-3 TON	14	17	20	2@ 12	2@ 10
482-0012 or 3	SADC-4 TON	14	17	23	2@ 16	2@ 12
602-0012 or 3	SADC-5 TON	14	17	27	4@ 10	4@ 8
362-016	Split Plenum	14	17	23	2 – 8"	
482-016	Split Plenum	14	17	27	2 – 9"	
602-0042 or 3	SADC-5 TONS	14	17	20		