

Wired Pump Relay Controllers

46001 / 46004 / 46006



For all priority situations

- You'll always have the right controller in the truck, with support for internal or external priority DHW calls in one device.
- Control up to 30 zones in a single boiler system.
- Reliable enough to carry a 5- year warranty

ComfortPro
AquaHeat
Radiant heating and snowmelting products

ComfortPro
AquaSeal
Pex piping and plumbing products

ComfortPro
AquaMelt
Snowmelt Systems

ComfortPro
Terre-Pex
Pre Insulated Pex-A Piping Systems

Description and Features

The SALUS Wired Pump Relay Controllers allow wired thermostats to control pumps and boilers for hydronic systems while supporting the following functions and features:

- Primary pump control
- Priority zone support (domestic hot water)
- Purge – Priority pump continues to run for 2 minutes after end of priority call
- Exercise – pumps turn ON for 30 sec. after 72 hours of inactivity
- Thermostat grouping
- ZC/ZR boiler enable support
- XX and AUX normally open contacts support
- Master / Slave function for up to 5 units (1 master / 4 slaves)
- LED indicators for zones and Priority status
- 3 models: 46001 – single zone
46004 – 4 zone
46006 - 6 zone

Example Wiring Diagram (46004)

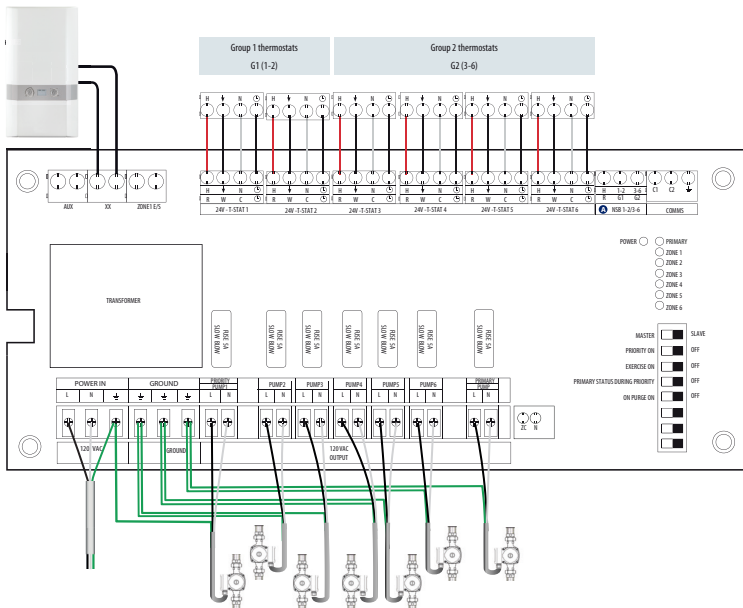

Specifications

	46001	46004	46006
Configuration Switches			
Master/Slave		✓	✓
Priority ON/OFF		✓	✓
Exercise ON/OFF		✓	✓
Primary Status During Priority ON/OFF		✓	✓
Purge ON/OFF		✓	✓
Indicators			
Power LED	✓	✓	✓
Priority LED		✓	✓
Zone LEDs (1 per zone)	1x	4x	6x
Terminals			
Power In (L, N) 120 VAC 50/60 Hz, max. 20 A.	✓	✓	✓
GND	1x	4x	4x
Primary Pump (L, N) max. 1/6 hp		✓	✓
Pumps (L, N) max. 1/6 hp	1x	4x	6x
Priority on Pump 1		✓	✓
AUX contacts		✓	✓
XX contacts, 120 VAC, 2 A max.	✓	✓	✓
ZONE1 E/S contacts		✓	✓
Wired Thermostat (R, W, C) 24 VAC, max 0.8A	1x	4x	6x
Night Setback (R, G1, G2)		✓	✓
Comm (C1, C2, gnd)		✓	✓
Mechanical			
Keyhole Screw Mounts	3x	4x	4x
3/4" cable knockouts	2x	11x	11x
	Weight	Dimensions	
46001	1.27 lbs, 0.58 kg	3.15" x 6.3" x 4.5" 80 x 160 x 114 mm	
46004	3.18 lbs, 1.44 kg	3.15" x 11" x 9.25" 80 x 280 x 235 mm	
NA	3.39 lbs, 1.54 kg		

Fuses: 5A slow blow, 5x15 mm (2AG)

Operating: 32° - 110° F, 0° - 43° C, 20 - 90% RH, non-condensing

Storage: 32° - 122° F, 0° - 50° C, 20 - 90% RH, non-condensing

Agency Compliance:

ETL certified to CSA C22-2 No. 24 and UL873

FCC, Industry Canada

CE: RoHS, REACH, WEEE

Warranty: 5 years limited warranty



AquaHeat
Radiant heating and snowmelting products



AquaSeal
Pex piping and plumbing products



AquaMelt
Snowmelt Systems



Terre-Pex
Pre Insulated Pex-A Piping Systems